

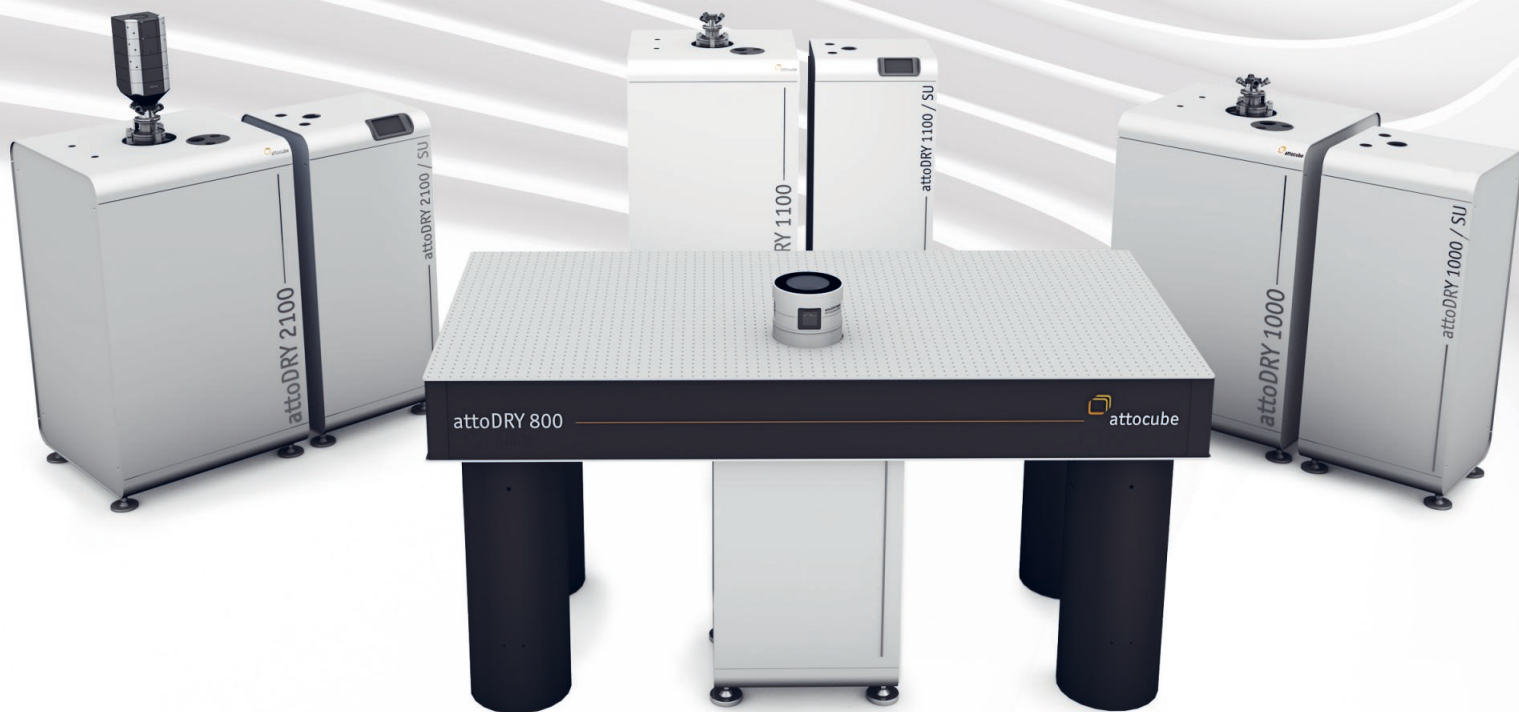

attocube

WITTENSTEIN group



attoDRY

Closed-cycle Cryostats

attoDRY

Closed-cycle Cryostats

The dependence on liquid helium continues to involve heavy logistics, high prices and insecure supplies. Consequently, closed-cycle cryostats are becoming more and more popular in all areas involving measurements at variable or low temperatures. With the attoDRY series, attocube provides unique instruments with unmatched and proven low mechanical vibrations, unprecedented low acoustic noise levels, and exceptional temperature stability.

Besides, our toploading systems have been optimized for fast turnaround times and hence enable a maximum number of measurement cycles in a minimum amount of time. Superconducting magnets as single solenoids or vector magnets are available for measurements in high magnetic fields. Last but not least, special emphasis has been put into the ease of use through automation of routine procedures, also contributing to a highly professional user experience.

Cryogen-free



Tired of helium costs? The attoDRY closed-cycle cryostats require no liquid helium at all, and hence liberate the user from the increasingly unreliable and ever-more expensive supply of liquid helium.

Large Sample Space



While most magnet systems feature only 1" diameter sample space, our toploading attoDRY cryostats provide twice the diameter. The attoDRY800 even offers more room at about 3" diameter. This leaves ample space for sophisticated cryogenic experiments and is of course compatible with our complete line of measurement options.

Automation & Touchscreen



Routine procedures such as temperature and magnetic field control are fully automated by a clever gas handling system consisting of integrated pumps, valves and electronics. Moreover, the attoDRY800, 1100 & 2100 are the first cryostats featuring an integrated touchscreen for intuitive control even without a PC.

Versatile Platform



A variety of measurement options is available, spanning from a fully 3-dimensional double rotator resistivity module to distinguished characterization techniques such as atomic/magnetic force microscopy (AFM/MFM), scanning Hall probe microscopy (SHPM), confocal microscopy (CFM) and micro-Raman.

Ultra-low Vibration



Due to a proprietary design, mechanical vibrations created by the coldhead are well decoupled from the measurement platform, thus enabling the use of sensitive techniques such as scanning probe microscopy in a dry low temperature environment.

Silent Operation



Special care was taken to reduce the acoustic noise of the inherently loud cold heads by an order of magnitude at the most relevant frequencies. This guarantees a pleasant working environment in your lab.

Fast Cooldown



Initial cooldown of a complete toploading system can be as fast as 5-10 hours (without magnet), whereas samples can be cooled within 1-2 hours. The attoDRY800 cryo-optical table with sample in vacuum features a cooldown time of approximately 3 hours.

Temperature Stability



The attoDRY cryostats enable precise temperature control over the complete range with a stability measured to be much better than +/- 10 mK at low temperatures. This enables long unattended measurement cycles during your experiment.

Overview attoDRY

compatibility chart

	attoDRY800	attoDRY1000	attoDRY1100	attoDRY2100
base temperature	3.8 K	4 K	4 K	1.65 K
temperature range	3.8..320K	4..300 K	4..300 K	1.65..300 K
cryogen-free	•	•	•	•
automation	•	•	•	•
superconducting magnets		•	•	•
superconducting vector magnets		•	•	•
superconducting split coil magnets		•	•	•
variable temperature	•	•	•	•
top-loading (sample in exchange gas)		•	•	•
vacuum loading (sample in vacuum)	•	on request		
optical access to sample	•	•	•	•
ultra low vibration	•	•	•	•
integrated positioners	optional	optional	optional	optional
compatibility with microscopes				
attoAFM I (incl. MFM, PFM, KPFM, ct-AFM...)		•	•	•
attoSHPM		•	•	•
attoCFM I	•	•	•	•
attoCFM II	optional	•	•	•
attoCFM III	optional	•	•	•
attoCFM IV	optional	•	•	•
attoRAMAN	•	•	•	•
attoAFM/CFM	on request	•	•	•
Photonic Probe Station	•			
attoAFM/STM				
attoAFM III		•	•	•
atto3DR		on request	on request	•



attoDRY800

cryo-optical table (closed-cycle)

Specifications

attoDRY800

NEW

Quantum optics experiments often require cryogenic temperatures in combination with optical access to the sample space. Most experimental setups contain numerous optical elements that need to be precisely arranged on an optical table to shape and prepare the incident light, as well as to efficiently collect and convert the emitted light from the sample. The available space on the optical table in such cases is of paramount importance to many complex setups.

The revolutionary concept and design of the attoDRY800 present the perfect solution to satisfy these demanding requirements: it consists of an ultra low vibration cold breadboard platform which is fully integrated into an optical table. The cryocooler assembly is located in the otherwise unused space underneath. This unique design ensures a free workspace and unobstructed optical access to the cold sample from all directions on the optical table. Apochromatic objectives with high numerical aperture (NA=0.81-0.95) can either be integrated into the cryostat, into the vacuum shield, or put in close working distance next to the optical windows from the outside. This ensures extremely low drifts and optimal collection efficiency.

Being a closed-cycle cryostat, the attoDRY800 is the perfect replacement for all helium flow cryostat setups, adding the huge advantage that it requires no liquid cryogens and thus minimizing running costs. In addition, a fully automated temperature control between 3.8 and 320 K conveniently enables unattended long measurement cycles.

Most other off-the-shelf closed-cycle cryostats suffer from severe vibrations at the sample location, which typically are in the range of many microns. Thanks to our patented vibration isolation technique, the residual vibrations on the cold plate of the attoDRY800 were measured to be around 2.6 nm peak-to-peak (vertical direction) only. Hence, with the attoDRY800 even extremely sensitive measurements are possible. Its cold breadboard sample space is designed to host several of attocube's patented nanopositioners, as well as complete microscope or photonic probe station solutions.



- 01 optical table (included)
- 02 cryocooler
- 03 cold breadboard
- 04 customizable vacuum shroud
- 05 touchscreen user interface
- 06 obstruction free work space

PRODUCT KEY FEATURES

- cold breadboard integrated into optical table
- low vibrations < 5 nm peak-to-peak
- fully automated variable temperature 3.8 .. 320 K
- customizable vacuum shroud

BENEFITS

- free workspace & obstruction-free optical access
- high sample throughput due to fast cooldown
- low running costs (no liquid cryogens)
- flexible combination with attocube equipment: patented cryogenic positioning solutions with multi-degrees of freedom

APPLICATION EXAMPLES

- quantum dot spectroscopy
- photocurrent / photoconductivity
- time-resolved spectroscopy
- reflectance / transmittance measurements
- micro-Raman imaging & spectroscopy
- optical resonators coupled to waveguides
- plasmonics on 2D materials
- resonant fluorescence
- optically detected nuclear magnetic resonance
- quantum information processing
- scanning probe microscopy

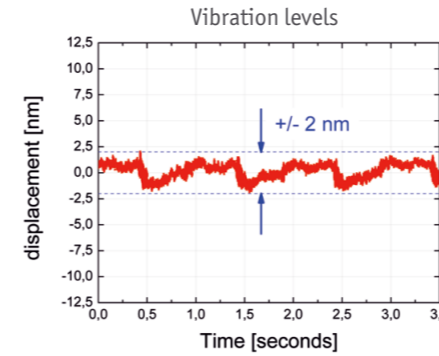

Application examples

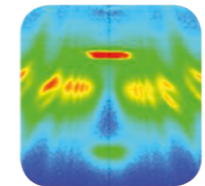

Quantum Dot Spectroscopy

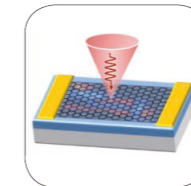

Photocurrent / Photoconductivity Measurements

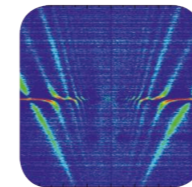

Micro-Raman Imaging / Spectroscopy

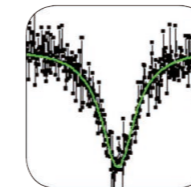

Optically Detected Nuclear Magnetic Resonance

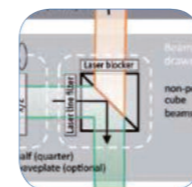

Resonant Fluorescence

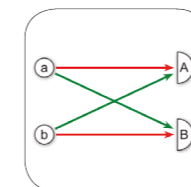

Quantum Information Processing



- **Obstruction free** work space
- **Optical table included** (different sizes available)
- 36 customer wires included, **heat sunk @ 4 K**
- Turbo pump incl., **base pressure in sample chamber < 5e-6 mbar**

General Specifications	
technology	ultra low vibration, closed-cycle cryostat intimately integrated into optical table, optical table included
sample environment	cryogenic vacuum, sample cooled via braids (ATC100)
sample space	75 mm (diameter)
sample exchange	easy access via removal of vacuum shroud
usability	fully automated temperature control (vacuum, cooldown, T control, warmup), all pumps integrated, USB interface for remote control
vibration & acoustic noise damping system	proprietary low vibration design
Performance Data	
temperature range	3.8 .. 320 K (depending on configuration)
base pressure (in sample chamber)	< 5e-6 mbar
leak rate of vacuum	< 5e-9 mbar l/s
cool down time (incl. pumping time)	< 4.5 h to 5 K (depending on thermal load)
temperature stability	< 15 mK (peak-to-peak with damped sample mount)
cooling power at sample location	> 170 mW @ 5 K
vibration level (cold plate, vertical)	< 5 nm (peak-to-peak @ 1500 Hz)
Closed-cycle cooler	
power consumption	max. 3 kW
cooling of compressor	water cooling (default; requires local infrastructure), air cooling (optional)
Size and Dimensions	
optical table	standard size 900 mm x 1800 mm x 305 mm (leg height 597 mm); metric or imperial mounting threads (other table sizes available)
Options and Upgrades	
temperature controller	included
pumping kit	included
vacuum shroud	Basic (standard shroud), RT-SWD, RT-USWD upgrade, LT-APO objective, HV objective, Photonic Probe Station, or customized height, diameter, windows & working distance
electrical access	36 customer wires included, heat sunk @ 4 K
feedthroughs	electrical (DC, HF), optical fibers, gas capillary (on request)
sample motion	Premium Line positioners and scanners
cryostat compressor upgrade	air-cooled (grey-room recommended)
flexlines	extension to 13 m or 20 m (instead of 6 m)
air-compressor	for active vibration isolation of optical table
Compatible Equipment	
confocal microscopes	attoCFM
confocal Raman microscopes	attoRAMAN (on request)

attoDRY800 Options

optional items for the cryo-optical table

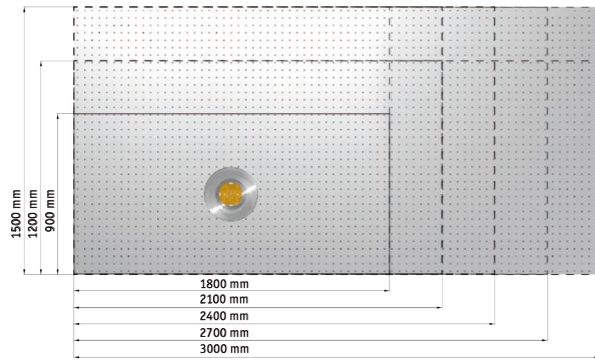

Decide on the table size

Customized Newport optical tables with metric M6 or imperial hole pattern are available with the following dimensions :

(other table sizes and solutions for integration with existing optical tables available on request)

Default size: 900 mm x 1800 mm Leg height: 597 mm, Table thickness: 305 mm	
1200 mm x 1800 mm	1500 x 1800 mm
1200 mm x 2100 mm	1500 x 2100 mm
1200 mm x 2400 mm	1500 x 2400 mm
1200 mm x 2700 mm	1500 x 2700 mm
1200 mm x 3000 mm	1500 x 3000 mm

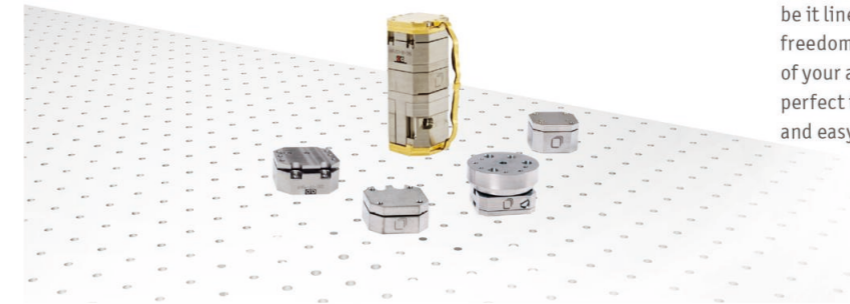

Add multiple degrees of freedom for sample motion

The attoDRY800 is predestined to host your choice of nanopositioners, be it linear, rotary, tilting or scanning stages. Combine many degrees of freedom, or more than one stack of positioners to fulfill all requirements of your application! With our dedicated ATC100 thermal link, we ensure a perfect thermalization of your sample that is straightforward to mount and easy to use.

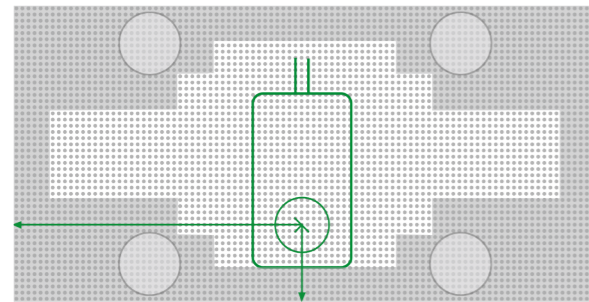

Choose location of cold breadboard

In order to optimally adapt the system to specific experimental needs, the location of the cold plate of the cryostat can be specified by the customer upon ordering. It can be placed as close as 200 mm to the long edge, as well as off-center with respect to the short edge on wider tables (depending on table size).

Contact attocube for more details.

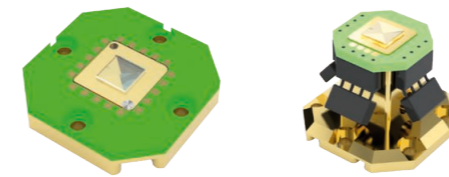

Sample holders

For users that require a sample holder with electrical contacts, attocube offers PCB based sample holders with 12 contacts. There are different options available for the respective vacuum shrouds and positioner configurations.

Article	Art.No.
ASH/PCB/12	1005710
ASH/SWD	1012785
ASH/Zvar	1013136
ASH/PCB/12mini	1013138

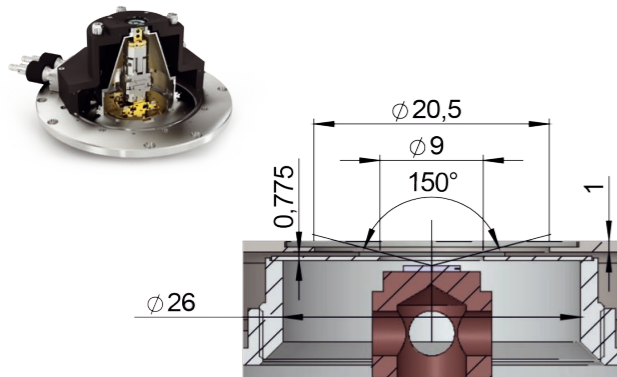

Ultra-short working distance

A popular option for flow cryostats is to bring the cold sample as close as possible to an ultra-low working distance window. This allows to flexibly use external optics with a very high angle of admittance, maximizing the collection efficiency via high numerical aperture objectives. The ultra-short working distance option (RT-USWD) is compatible with xyz positioners and xy scanner, and features a min. working distance of 2 mm (1 mm) with (without) cold window installed.

Article	Art.No.
RT-SWD option	1011252
RT-USWD upgrade	1013109



Electrical and optical feedthrough options

Additional wiring can be provided upon ordering directly through the cryostat, with convenient electrical access at pin connectors close to the sample in vacuum for customer use. Additional wiring can be also provided upon pre-wired and interfaced directly to the cold plate.

etrofit extra wiring or optical feedthroughs are possible via electrical feedthroughs in an adapter ring at the bottom of the sample chamber.

Article	
Electrical access in vacuum	12 wires, terminated in vacuum
Pre-wired to cold plate	12 wires, low resistance, compatible with nanopositioners
Coaxial feedthroughs	2 or 4 SMA connectors
Fiber feedthroughs	1, 2 or 4 FC/APC or FC/PC connectors

Proven Low Vibrations

attoDRY800 selected measurements

Selected Application

attoDRY800

Vibration measurements on cold plate of attoDRY800

The interferometric measurements to the left show vertical & horizontal displacement data measured directly on the cold plate of the attoDRY800. The peak-to-peak vibrations in vertical direction are around 3 nm (4 nm), while in lateral direction they are around 2 nm (17 nm) in a bandwidth of 200 Hz (1500 Hz). This very efficient and unique low vibration design even allows for very sensitive optical measurements such as optical probe stations or high resolution optical spectroscopy on nanostructures.

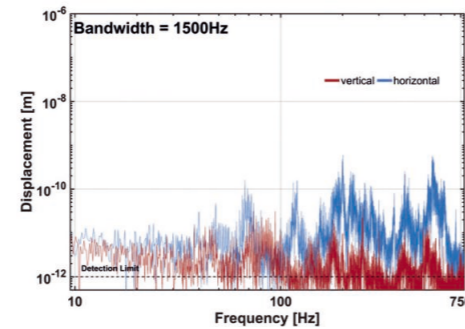
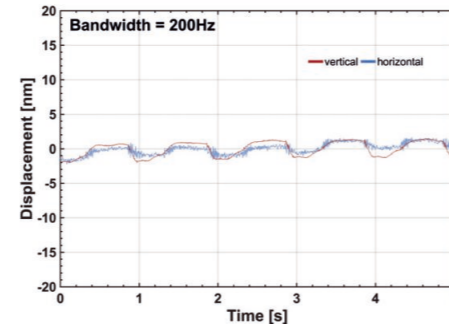
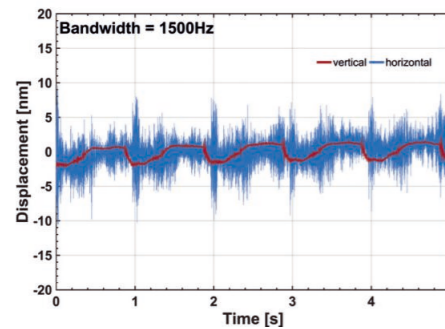

Direction	Peak-to-Peak @200 Hz (1500 Hz)	RMS @200 Hz (1500 Hz)
vertical	3 nm (4 nm)	1.0 nm (1.1 nm)
horizontal	2 nm (17 nm)	0.6 nm (2.1 nm)

The FFT of the data above is shown to the left as well for both directions, vertical and horizontal respectively, at a bandwidth of 1500 Hz. The dashed line at 1 pm indicates the noise floor of the interferometer.

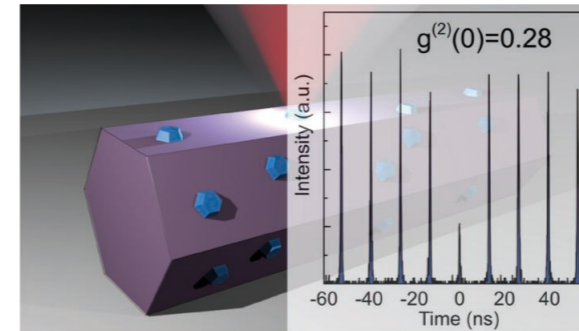

Single Photon Generation with Controlled Polarization from InGaN Quantum Dots

The research groups led by Prof. R. Taylor & Dr. R.A. Oliver in the UK have successfully generated single-photons with polarized light emission and predefined polarization axis at temperatures spanning from around 5 K to above 200 K using InGaN quantum dots. These quantum dots offer several advantages, such as high experimental repetition rates in the range of GHz, and for their growth as a planar structure, a single routine without complex geometrical engineering.

The emission spectra of these quantum dots were characterized using micro-photoluminescence techniques, while the samples were kept cool inside an optical cryostat equipped with attocube positioners. This cryostat, the attoDRY800, is able to reach temperatures ranges from below 5 K up to even above 300 K with very good thermal and vibrational stability.

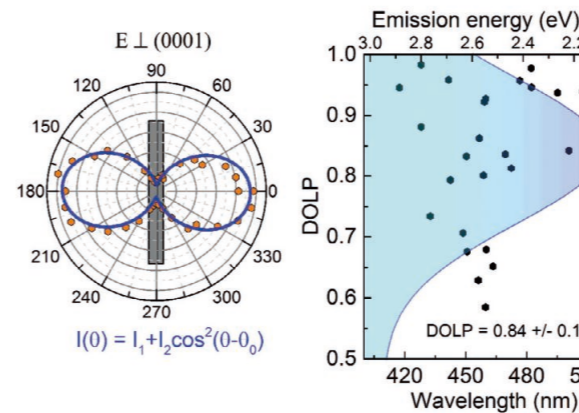

The single-photons generated by these quantum dots are bright enough to allow their optical properties to be measured even above 200 K, a temperature considered to be the Peltier cooling barrier. Hence, this suggests in principle, that these quantum dots could be applied in integrated electronic circuits. And thanks to the achievable polarization control, these quantum dots are good candidates for on-chip polarization encoding in quantum cryptography.

To know more about the work done by Robert Taylor, Rachel Oliver and their research teams, please visit their websites here: <https://users.physics.ox.ac.uk/~rtaylor/> and here <http://www.gan.msm.cam.ac.uk/directory/oliver> [Data courtesy of R. Taylor, Oxford University]

Further reading:
 [1] T. J. Puchler, R. A Taylor, et al. *Nanoscale* 2017, 9, 9421-9427
 [2] T. Wang, T. J. Puchler et al. *Nanophotonics*. DOI 10.1515/nanoph-2017-0027
 [3] T. Wang, T. J. Puchler *Phys. Status Solidi B*, 1600724 (2017)

CUSTOMER FEEDBACK

Dr. Heindel

Our group is working on quantum optics experiments exploiting deterministic quantum light sources based on semiconductor quantum dots. The two attoDRY800 systems will be used to probe the mutual two-photon interference of remote quantum emitter located in both cryostats. We are keen on the exciting experiments possible with these very stable cryostat systems.

(TU Berlin, Institute of Solid State Physics, Berlin, Germany)

CUSTOMER FEEDBACK

Dr. M. Kroner

The attoDRY800 setup is ideal for phase contrast microscopy as it allows free space optical access to the sample from both sides and makes it easily possible to investigate the transmitted light in momentum and real space excellent!

(Institute for Quantum Electronics, ETH Zurich, Switzerland)

CUSTOMER FEEDBACK

Prof. R. A. Taylor

I have to say we are very pleased with the attoDRY800 and have collected a good deal of data already.

(University of Oxford, Department of Physics, Oxford, Great Britain)

attoDRY800 Vacuum Shrouds

introduction

The idea behind the world's first cryo-optical table is that the user receives a high quality optical table from  Newport of his choice, which has an integrated cold plate of 75 mm in diameter. The cryostat is an integral part of the table, and comes in a standard configuration. The position of this cold plate can be chosen upon order.

Anything above the table surface can be customized according to the technical requirements and preferences of the user and his/her application. From more than 25 years working at the forefront of cryogenic optics applications, as well as learning from our users, and anticipating typical configurations, we have designed several standard vacuum

shrouds and cold shields, that are intended for certain types of positioners, sample holders, working distances and objectives. These options constitute an economic pre-configured set of components that give the user a head start for his research with optics at low and variable temperatures.

Most of our standard shrouds feature clever extensions by default, such as a feedthrough ring for optional additional DC, SMA and fiber feedthroughs, as well as a 30 mm and 60 mm cage system with quick release adapters centered around the top window.

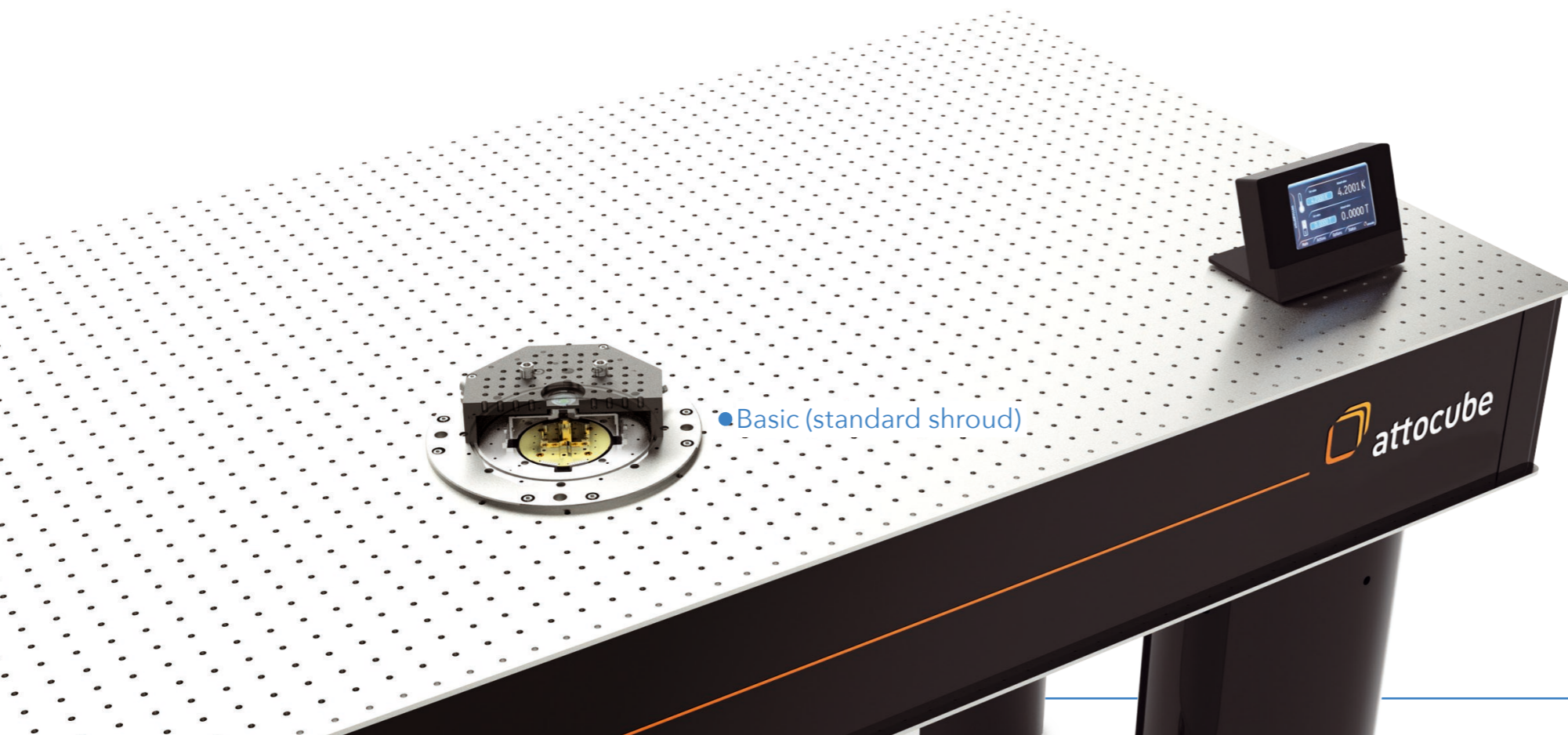

● Basic (standard shroud)

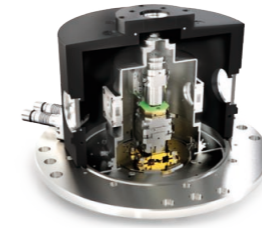

LT-APO objective

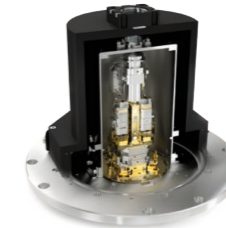

Photonic Probe Station

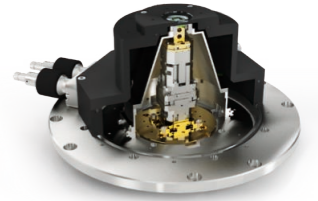

RT-SWD (RT-USWD)

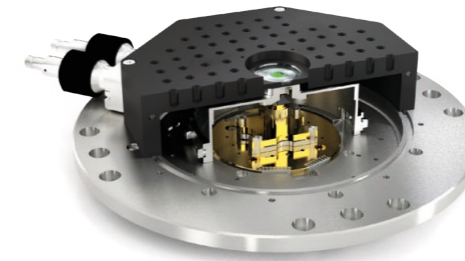

● Basic (standard shroud)
included with basic configuration*

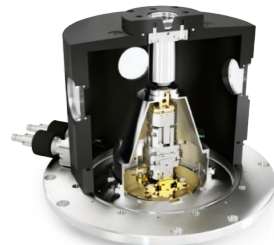

HV objective

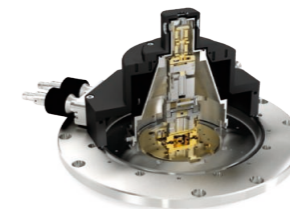

Customized
(5 window free-beam access LWD)

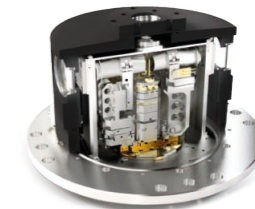

Customized
(LT-APO transmission)

*if no other shroud is bought

attoDRY800 Vacuum Shrouds

overview of different options



Basic (standard shroud)

By default, and if no other option is chosen, the attoDRY800 cryostat is delivered with the basic vacuum shroud. It constitutes a geometry which is almost identical to what hundreds of labs worldwide have been using for decades with their flow cryostats. Designed for room temperature optics, the sample sits on a manually adjustable holder at a typ. minimum working distance of about 3.5 mm. In addition to 88x M6 breadboard mounting holes on a 12.5 mm grid, it also features a 30 mm and 60 mm cage system threads and adapters.

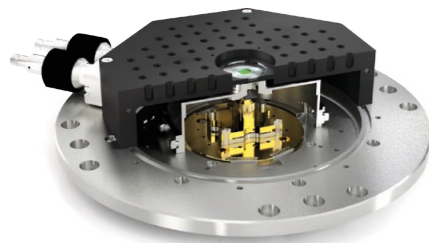

RT-SWD (RT-USWD)

The RT-SWD vacuum shroud constitutes the standard solution for using a short working distance objective at room temperature with a cold sample sitting on a stack of xyz positioners with optional scanner and sample holder with optional electrical contacts. It also features a 30 mm and 60 mm cage system threads and adapters.

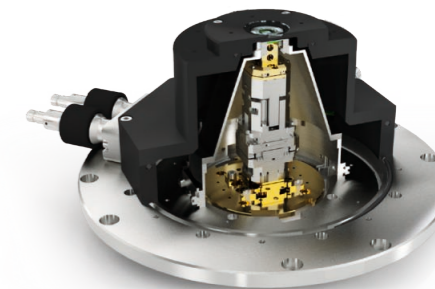

LT-APO objective

Our unique LT-APO low temperature objectives with high numerical apertures allow to maximize the collection efficiency over a broad wavelength range when optical signals are weak such as from single photon sources. Since sample and objective are both cold, this configuration also maximizes the overall stability of the setup. In the standard configuration, the sample sits on an xy positioner stack with optional scanner, while a z-positioner on the objective mount serves for focussing motion.

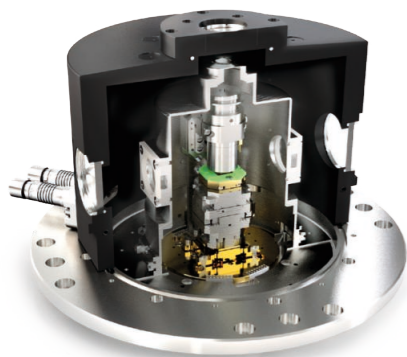

HV objective

Although the depth of focus decreases rapidly with increasing numerical aperture, hence limiting the chromatic useful range, some people prefer to work at ultimately high numerical apertures. This increases collection efficiency, and reduces integration time. The attoDRY800 HV high vacuum objective shroud allows for integration of any standard RMS (45 mm length) high vacuum compatible objective. The cold sample is sitting on a stack of xyz positioners and optional scanner and sample holder with optional electrical contacts.

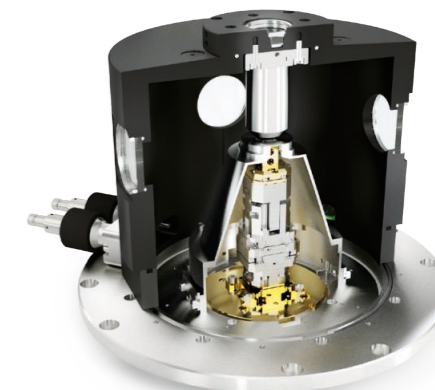

Photonic Probe Station

Photonic Integrated Circuits (PIC) are hot candidates for becoming the key components of the next generation of optical and quantum communication systems. The Photonic Probe Station vacuum shroud allows for integration of two optical lensed-fiber probes from the side for coupling light into planar waveguides, and a free-beam confocal top access for nano photonic device characterization. In addition, the vacuum shroud offers side access with an additional room temperature objective from the outside.



Customized

As previously described, the strength of the attoDRY800 cryo-optical table is that anything above the cold plate can be customized. For example, we have integrated two LT-APO cold objectives for transmission measurements. Due to the 8 side windows, the user can alternatively also observe wide-angle scattering and collect light from the outside. Both objectives are carefully thermalized, and 7 degrees of freedom given by xyz positioners allow for independent control of sample position and both objective focal spots on the sample. Another customized shroud features 5 optical windows with minimal working distance from all sides for room temperature objectives.



Basic (Standard Shroud)

basic vacuum shroud for use with a room temperature objective



RT-SWD (RT-USWD)

vacuum shroud for use with room temperature objective and positioners

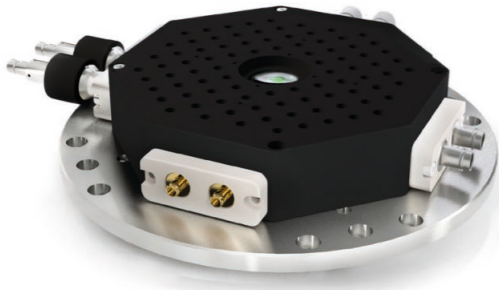

PRODUCT KEY FEATURES

- included with attoDRY800 base configuration at no additional cost!*
- corresponds to the classical flow cryostat configuration
- 88xM6 breadboard mounting holes
- compatible with 30 mm & 60 mm cage system
- optional sample holder with manually adjustable height, and 12 optional electrical contacts
- feedthrough ring with blind flanges included, DC/SMA/fiber feedthroughs optional
- not compatible with positioners, see e.g. RT-SWD or others

*no additional cost only in case no other vacuum shroud is purchased

PRODUCT KEY FEATURES

- standard configuration for use with external RT objective and xyz positioners (+optional scanner)
- Ultra-short working distance upgrade available (1 mm / 2 mm)
- compatible with 30 mm & 60 mm cage system
- optional sample holder with 12 optional electrical contacts; temp. sensor & heater included
- feedthrough ring with blind flanges included, DC/SMA/fiber feedthroughs optional

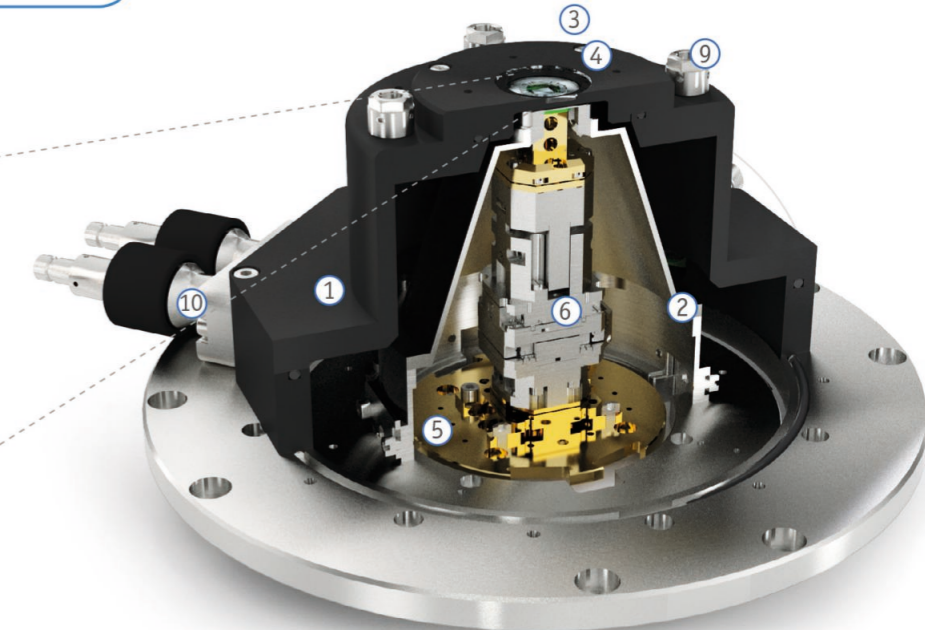
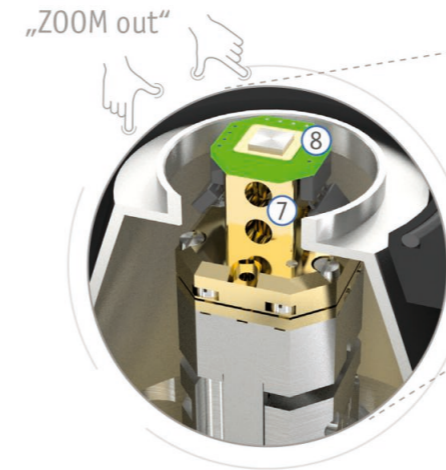
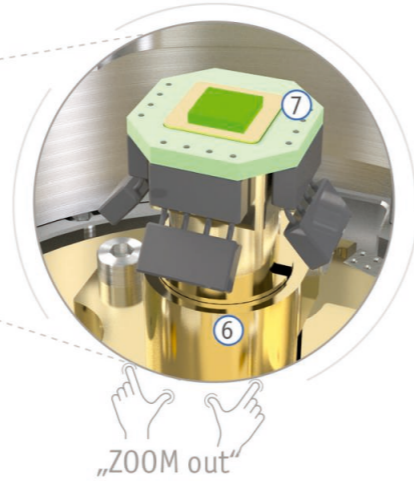
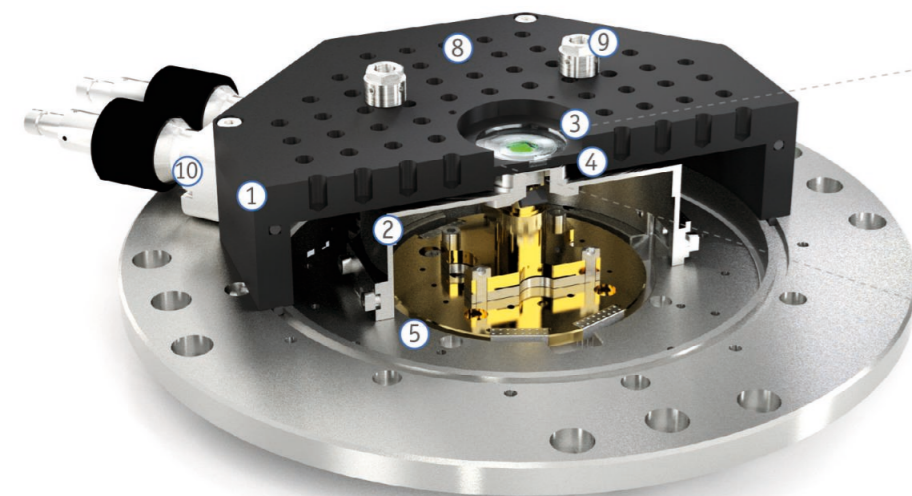

- 1 attoDRY800 basic vacuum shroud for use with room temperature objective (max. objective outer diameter 36 mm)
- 2 cold shield with top lid adjustable for min. working distance
- 3 vacuum top window, 25 mm x 1.5 mm, fused silica (others on request)
- 4 default min. working distance of 3.5 mm (others on request); cold shield top window, 12.7 mm x 0.5 mm, fused silica (others on request); default cold shield clear aperture 9 mm (3, 6 11, 14 mm on request)
- 5 cold plate

- 6 ASH/Zvar sample holder with +/-7 mm manual z range
- 7 ASH/PCB/12mini for ASH/Zvar with 12 electrical contacts wired to twisted pairs
- 8 88x M6 breadboard mounting holes on lid (12.5 mm grid)
- 9 30 mm x 30 mm & 60 mm x 60 mm cage system mounting threads centered around top window; 4x cage rod mounting adapters for quick removal included
- 10 feedthrough ring with blind flanges included, DC/SMA/fiber feedthroughs optional

- 1 attoDRY800 RT-SWD vacuum shroud for use with room temperature objective; default min. working distance < 4 mm (others on request, see also USWD option with 2 mm (1 mm))
- 2 cold shield with top lid adjustable for min. working distance
- 3 vacuum top window, 25 mm x 1.5 mm, fused silica (others on request)
- 4 cold shield top window, 12.7 mm x 0.375 mm, fused silica (others on request); default cold shield clear aperture 9 mm (3, 6 11, 14 mm on request)
- 5 cold plate

- 6 ANPxy311/ANPz102 positioners + ATC100/Si thermal link with integrated Si diode & heater + optional ANSxy100
- 7 ASH/SWD sample holder for attoDRY800
- 8 ASH/PCB/12mini for ASH/SWD with 12 electrical contacts wired to twisted pairs
- 9 30 mm x 30 mm & 60 mm x 60 mm cage system mounting threads centered around top window; 4x cage rod mounting adapters for quick removal included
- 10 feedthrough ring with blind flanges included, DC/SMA/fiber feedthroughs optional

NEW

LT-APO Objective

vacuum shroud for use with low temperature objective



HV Objective

vacuum shroud for use with vacuum objectives

NEW

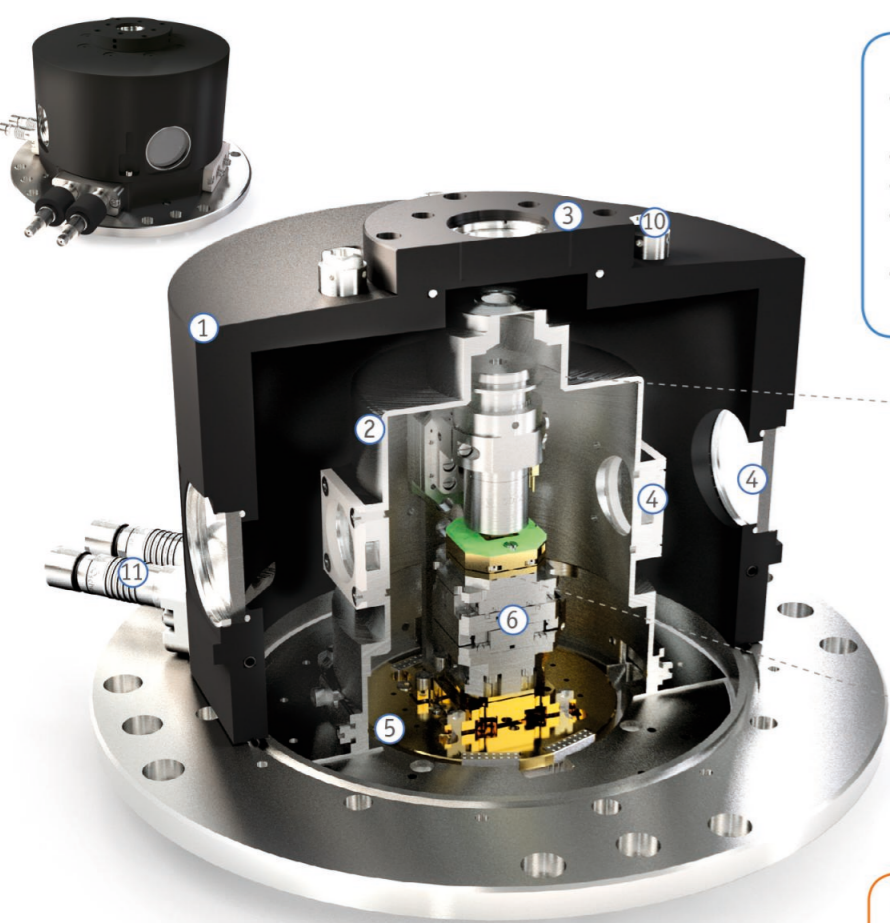

- PRODUCT KEY FEATURES**
- standard configuration for use with internal LT-APO low temperature objective and xyz positioners (+ optional scanner)
 - minimal sample drift, broadband high collection efficiency
 - compatible with 30 mm & 60 mm cage system
 - optional sample holder with 12 optional electrical contacts; temp. sensor & heater included
 - feedthrough ring with blind flanges included, DC/SMA/fiber feedthroughs optional

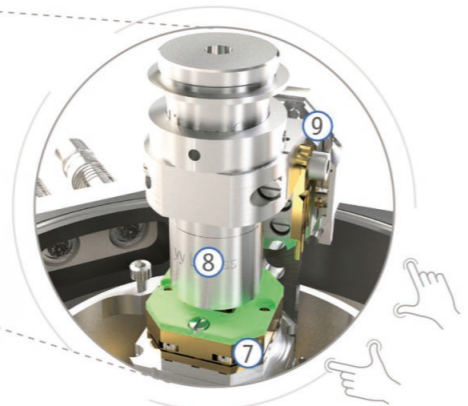

„ZOOM out“



Cryogenic Apochromatic Objectives

- negligible chromatic focal shift in working range
- uniform spot size and intensity within apochromatic range

- PRODUCT KEY FEATURES**
- standard configuration for use with internal high vacuum objective and xyz positioners (+ optional scanner)
 - compatible with 30 mm & 60 mm cage system
 - optional sample holder with 12 optional electrical contacts; temp. sensor & heater included
 - feedthrough ring with blind flanges included, DC/SMA/fiber feedthroughs optional

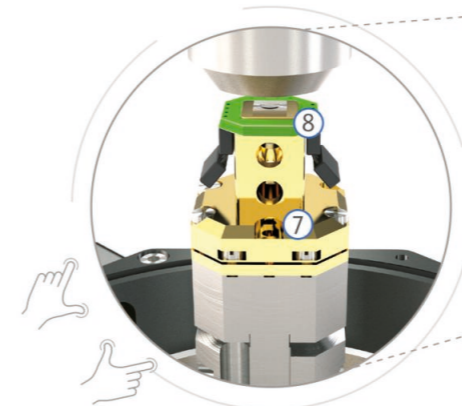

„ZOOM out“

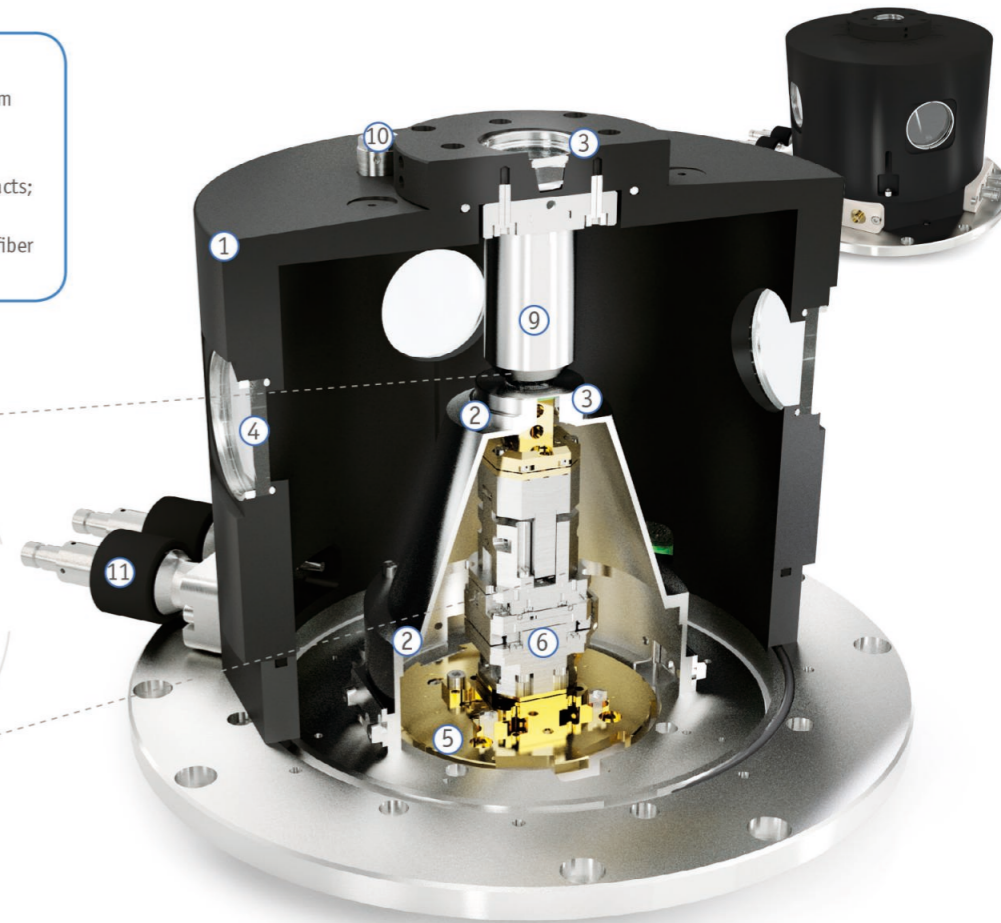

- ① attoDRY800 LT-APO vacuum shroud for use with low temperature objective
- ② cold shield
- ③ top vacuum window 25 mm x 1.5 mm, cold shield top window 12.7 mm x 0.375
- ④ 4x side vacuum windows 40 mm x 4 mm, 4x cold shield windows 25 mm x 4 mm; window material fused silica (others on request)
- ⑤ cold plate
- ⑥ ANPxy311 positioners + ATC100/Si thermal link with integrated Si diode & heater + optional ANSxy100 scanner

- ⑦ ASH/PCB/12 with 12 optional electrical contacts wired to twisted pairs
- ⑧ LT-APO objective on separate mounting post
- ⑨ ANPz311 for z focus of objective with thermal link for objective
- ⑩ 30 mm x 30 mm & 60 mm x 60 mm cage system mounting threads centered around top window; 4x c moval included
- ⑪ feedthrough ring with blind flanges included, DC/SMA/fiber feedthroughs optional

- ① attoDRY800 HV objective vacuum shroud for use with high vacuum compatible objective
- ② cold shield with top lid adjustable for min. working distance
- ③ top vacuum window 25 mm x 1.5 mm, cold shield top window 12.7 mm x 0.375; window material fused silica (others on request)
- ④ 4x side vacuum windows 40 mm x 4 mm
- ⑤ cold plate
- ⑥ ANPxy311/ANPz102 positioners + ATC100/Si thermal link with integrated Si diode & heater + optional ANSxy100 scanner

- ⑦ ASH/SWD sample holder for attoDRY800
- ⑧ ASH/PCB/12mini for ASH/SWD with 12 electrical contacts wired to twisted pairs
- ⑨ HV compatible, RMS standard objective with 45 mm length; several objectives available on request (NA = 0.75 .. 0.95)
- ⑩ 30 mm x 30 mm & 60 mm x 60 mm cage system mounting threads centered around top window; 4x cage rod mounting adapters for quick removal included
- ⑪ feedthrough ring with blind flanges included, DC/SMA/fiber feedthroughs optional

NEW

Photonic Probe Station

vacuum shroud for photonic probe station incl. optical side access



Customized Vacuum Shrouds

attoDRY800

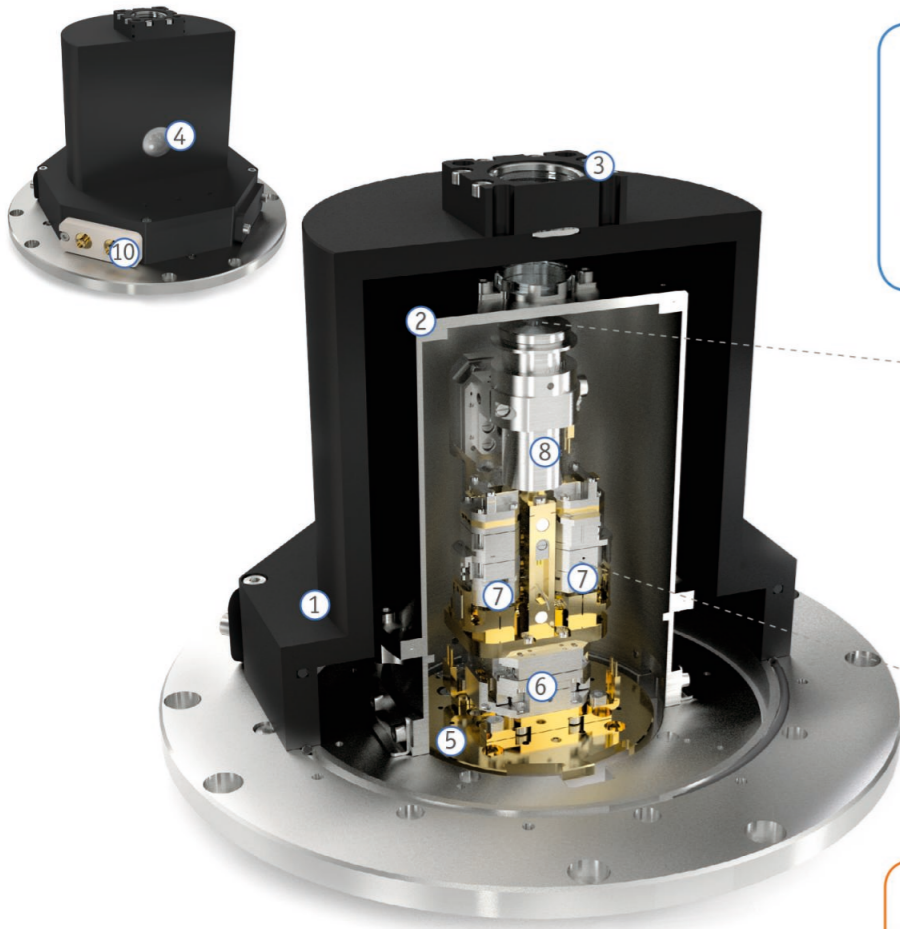

- PRODUCT KEY FEATURES**
- Vacuum shroud for use with internal LT-APO low temperature objective and lensed-fiber probes for side illumination & detection of waveguide structures
 - minimal sample drift, broadband high collection efficiency
 - Sufficient space for 9 degrees of freedom to independently position sample, focus, and 2 fiber probes
 - Side access with additional window for RT optics

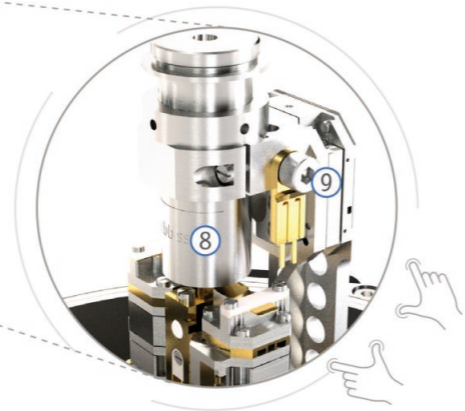

„ZOOM out“



- Cryogenic Apochromatic Objectives**
- negligible chromatic focal shift in working range
 - uniform spot size and intensity within apochromatic range

- ① attoDRY800 vacuum shroud for photonic probe station setup
- ② cold shield
- ③ top vacuum window 25 mm, cold shield top window 20 mm
- ④ additional window for side inspection 25 mm x 1 mm; window material fused silica or N-BK7 (others on request)
- ⑤ cold plate

- ⑥ ANPx311/RES positioners for xy translation of sample and fiber probes
- ⑦ 2x ANPx51/RES for xyz translation of fiber probes
- ⑧ LT-APO objective on separate mounting post
- ⑨ ANPx311 for z focus of objective with thermal link for objective
- ⑩ feedthrough ring with blind flanges included, DC/SMA/fiber feedthroughs optional

customized shroud for transmission with two LT-APO objectives



- PRODUCT KEY FEATURES**
- Vacuum shroud for use with 2 horizontal internal LT-APO low temperature objective
 - Sufficient space for 7 degrees of freedom to independently position sample and 2x focal spot
 - 8 side windows for scattering and transmission



customized shroud for free-beam access from 5 sides with low working distance



- PRODUCT KEY FEATURES**
- Vacuum shroud for use with up to 5 room temperature objectives
 - Low working distance from 5 sides
 - Compatible with low temperature positioners (xyz) and/or scanner (xyz)

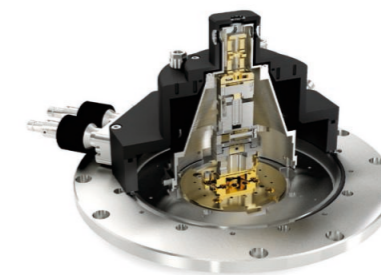

i Contact us for other customizations!

attoDRY1000

cryogen free cryostat with optional superconducting magnets

The attoDRY1000 is a cryogen-free cooling system setting new performance benchmarks. The attoDRY1000 was specifically designed to provide an ultra-low vibration measurement platform for cryogenic scanning probe experiments without the need for liquid helium. The standard closed-cycle system enables vibration-sensitive experiments in a temperature range from 4 K to 300 K. The optionally available microscope inserts are cooled by a controlled exchange gas atmosphere. Superconducting magnets up to 9 T are available as an option. Due to a proprietary design, mechanical vibrations created by the pulse-tube coldhead are decoupled from the measurement platform.

When measured with the attoAFM I, vibration amplitudes of less than 0.15 nm RMS are routinely achieved (bandwidth of 200 Hz, vertical direction)*. Despite the mechanical decoupling between coldhead and sample platform, the cooling performance of the attoDRY1000 is simply outstanding. Temperatures as low as 3 K and probe cooldown times as fast as 1 hour make cryogenic scanning probe experiments a delight. For the attoDRY1000, a wide variety of scanning probe microscopy inserts is available, ranging from confocal (CFM) to magnetic force microscopy (MFM).

*Further reading: F.P. Quacquarelli *et al.*, arXiv:1404.2046v1

Cryogen-Free. Low Vibration.

exceptional temperature performance

CUSTOMER FEEDBACK

Prof. M. Atatüre

Since the installation of the attoDRY1000 in our lab, all quoted specifications were fulfilled or exceeded and the service and support have proven to be excellent. The unit has been operational since the first day and continues to function with no interruptions. I can verify that, in contrast to typical liquid systems, the attoDRY1000 continues to operate without the typical interruption of cryogenics refill, allowing data acquisition around the clock for months.

(University of Cambridge, Department of Physics, UK)

COOLDOWN TIME

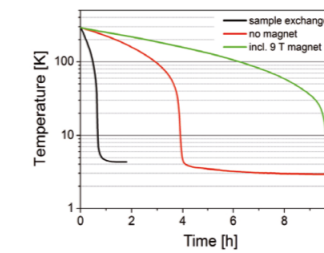

TEMPERATURE STABILITY

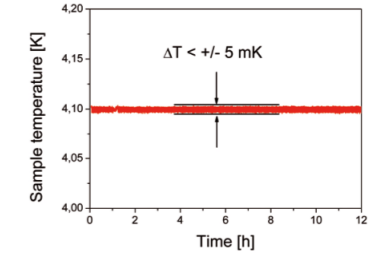

General Specifications	
technology	ultra-low vibration, pulse-tube based closed-cycle cryostat designed for scanning probe microscopy applications
sample environment	He exchange gas
sample space	49.7 mm diameter probe bore fitting all attocube inserts
sample exchange	top loading system for quick access
vibration & acoustic noise damping system	proprietary low vibration design
Performance Data*	
temperature range	4 .. 300 K (opt. temp. controller required)
cool down time of sample	approx. 2 h (depending on insert)
cool down time of system (system without magnet)	approx. 5 .. 10 h (unattended)
cool down time of system (system incl. 9 T magnet)	approx. 10 .. 15 h (unattended)
temperature stability	< ± 10 mK expected (4 .. 50 K) < ± 25 mK guaranteed (4 .. 50 K)
cooling power at sample location	> 5 mW @ 5 K
Closed-cycle cooler	
nominal cooling power (4.2 K)	> 900 mW
power consumption	max. 9.0 kW, 7.2 kW steady state
cooling of compressor	water cooling (requires local infrastructure)
Dimensions	
cryostat (width x depth x height)	1120 x 640 x 1050 mm ³ (depending on magnet choice)
optional electronics rack (width x depth x height)	640 x 640 x 1050 mm ³
Options	
superconducting magnet	solenoids: 7, 9, 12 T vector magnets: e.g.: 8/2 T, 9/3 T, 9/1/1 T, ...
bipolar magnet power supply	included (with optional magnet)
temperature controller	2 channel (magnet + sample temperature)
pumping kit	turbomolecular pump with suitable backing pump for sample space preparation

*Note: All product specifications are based on a standard system. Optional items or upgrades, other configurations or customization may change one or several of the indicated values. Specifications and other information subject to change without notice.

Application examples

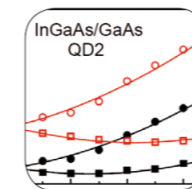

Confocal Imaging

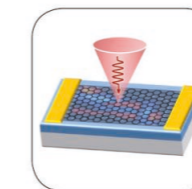

Photocurrent

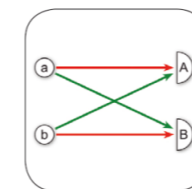

Quantum Information Processing

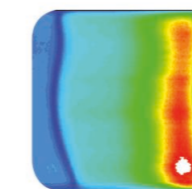

Photoluminescence Spectroscopy

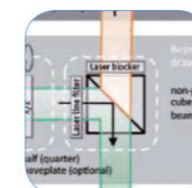

Resonant Fluorescence

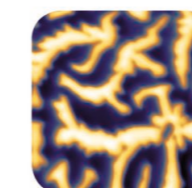

Kerr-Effect Measurements

PRODUCT KEY FEATURES

- cryogen-free, low vibration cryostat platform
- very fast cooldown and turn-around times
- temperature control range: 4 K to 300 K
- optional superconducting magnets

BENEFITS

- scanning probe microscopy experiments in a cryogen-free, low vibration environment
- fast exchange of samples and/or scanning probe tips
- measurements at a broad range of temperature and magnetic field (optional) with highest stability

APPLICATION EXAMPLES

- solid state physics and quantum dot optics
- material science research on ceramics, polymers, additives, alloys, ...
- semiconductor device characterization

COMPATIBLE MICROSCOPE SYSTEMS

- attoCFM I, attoCFM II, attoCFM III, attoRAMAN, attoAFM I, attoMFM I, attoSHPM
- attoAFM/CFM (on request)



attoDRY1100

touchscreen control of field & temperature

The attoDRY1100 offers a truly unique low temperature measurement platform with a fully automated gas handling system. The integrated touchscreen allows for conveniently setting the desired field (B) and temperature (T) without even using a PC. More elaborate measurement schemes such as programmable sweeps of B and T are easily possible via a USB connection and a LabVIEW interface.

The toploading design enables quick and easy sample exchange, while offering a generous sample space of 49.7 mm in diameter. The unmatched cooling performance via exchange gas coupling enables probe cooldown times as fast as 1-2 hours, and the initial cooldown time of the complete system is around 10-15 hours including a 9T magnet.

The temperature stability was measured to be better than ± 5 mK over 14 hours at 4 K.

Last but not least, the attoDRY1100 was specifically designed to provide an ultra-low vibration measurement platform for cryogenic scanning probe experiments without the need for liquid helium. Due to a proprietary design, mechanical vibrations created by the pulse-tube coldhead are decoupled from the measurement platform. When measured with the attoAFM I, vibration amplitudes of less than 0.15 nm RMS are routinely achieved (bandwidth of 200 Hz, vertical direction)*.

*Further reading: F.P. Quacquarelli *et al.*, arXiv:1404.2046v1



PRODUCT KEY FEATURES

- scanning probe microscopy experiments in a cryogen-free, low vibration environment
- fast exchange of samples and/or scanning probe tips
- measurements at a broad range of temperature and magnetic field (optional) with highest stability

BENEFITS

- no liquid helium required
- integrated 4.3" touchscreen
- full automation of field and temperature control
- USB/Ethernet interface, LabVIEW control
- designed for vibration sensitive measurements
- *in-situ* double rotator for full field (9 T) in 3D (optional)

APPLICATION EXAMPLES

- solid state physics and quantum dot optics
- material science research on ceramics, polymers, additives, alloys, ..
- semiconductor device characterization

COMPATIBLE MICROSCOPE SYSTEMS

- attoAFM I, attoMFM I, attoSHPM, attoAFM III, attoCFM I, attoCFM II, attoCFM III, attoRAMAN
- attoAFM/CFM (on request)

Application examples

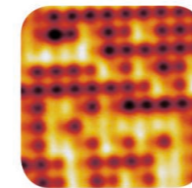

Magnetic Domain Imaging

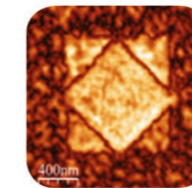

Piezoresponse Force Microscopy

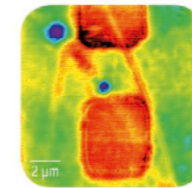

Kelvin Probe Force Microscopy

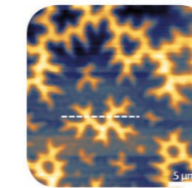

Scanning Hall Probe Microscopy

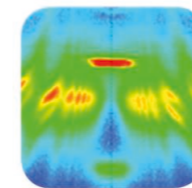

Quantum Dot Spectroscopy

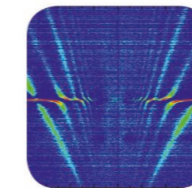

Micro-Raman Spectroscopy

Fully Automated. Turnkey Operation.

exceptional cooling performance

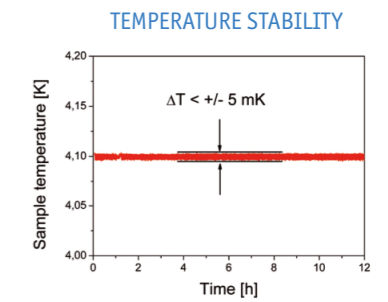
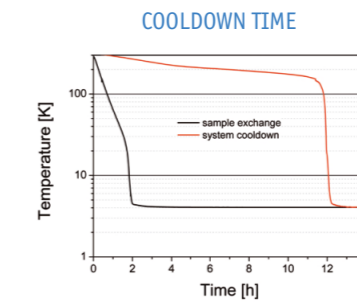

General Specifications	
technology	ultra-low vibration, pulse-tube based closed-cycle cryostat designed for scanning probe microscopy applications
sample environment	He exchange gas
sample space	49.7 mm diameter probe bore fitting all attocube inserts
sample exchange	top loading system for quick access
vibration & acoustic noise damping system	proprietary low vibration design
usability	fully automated temperature and magnetic field control via integrated touchscreen, USB interface for remote control
Performance Data*	
temperature range	4 .. 300 K
cool down time of sample	approx. 2 h (depending on insert)
cool down time of system (system without magnet)	approx. 5 .. 10 h (unattended)
cool down time of system (system incl. 9 T magnet)	approx. 10 .. 15 h (unattended)
temperature stability	< ± 10 mK expected (4 .. 50 K) < ± 25 mK guaranteed (4 .. 50 K)
cooling power at sample location	> 5 mW @ 5 K
Closed-cycle cooler	
nominal cooling power (4.2 K)	> 900 mW
power consumption	max. 9.0 kW, 7.2 kW steady state
cooling of compressor	water cooling (requires local infrastructure)
Dimensions	
cryostat (width x depth x height)	1120 x 640 x 1050 mm ³ (depending on magnet choice)
optional electronics rack (width x depth x height)	640 x 640 x 1050 mm ³
Options	
superconducting magnet	9 T
bipolar magnet power supply	included (with optional magnet)
temperature controller	included
pumping kit	included

*Note: All product specifications are based on a standard system. Optional items or upgrades, other configurations or customization may change one or several of the indicated values. Specifications and other information subject to change without notice.

attoDRY2100

cryogen free 1.65 K cryostat with optional superconducting magnet

Our range of toploading, dry, low vibration cryostats has been further extended by the attoDRY2100. It offers a continuous base temperature of 1.65 K, a automated temperature & magnetic field control from 1.65 K to 300 K and your choice of superconducting magnet.

The integrated touchscreen allows to conveniently set the desired field (B) and temperature (T) without even using a PC. More elaborate measurement schemes such as programmable sweeps of B and T are easily possible via a USB connection and a LabVIEW interface. The temperature stability was measured to be better than ± 5 mK at 1.5 K over 10 hours. The toploading design enables quick and easy sample exchange, while offering a generous sample space of 49.7 mm in diameter. The unmatched cooling performance via exchange gas coupling provides

an initial cooldown time of the complete system of around 15-20 hours, while the turn-around time during sample exchange is around 5-8 hours.

Last but not least, the attoDRY2100 was specifically designed to provide an ultra-low vibration measurement platform for cryogenic scanning probe experiments without the need for liquid helium. Due to a proprietary design, mechanical vibrations created by the pulse-tube coldhead are decoupled from the measurement platform. When measured with the attoAFM I, vibration amplitudes of less than 0.15 nm RMS are routinely achieved (bandwidth of 200 Hz, vertical direction)*.

*Further reading: F.P. Quacquarelli *et al.*, arXiv:1404.2046v1



PRODUCT KEY FEATURES

- continuous 1.65 K operation with automated gas handling
- cryogen-free, low vibration cryostat platform
- very fast cooldown and turn-around times
- temperature control range: 1.65 K to 300 K
- optional superconducting magnets up to 9 T

BENEFITS

- scanning probe microscopy experiments in a cryogen-free, low vibration environment
- fast exchange of samples and/or scanning probe tips
- measurements at a broad range of temperature and magnetic field (optional) with highest stability

APPLICATION EXAMPLES

- solid state physics and quantum dot optics
- material science research on ceramics, polymers, additives, alloys, ..
- semiconductor device characterization

COMPATIBLE MICROSCOPE SYSTEMS

- attoAFM I, attoMFM I, attoSHPM, attoAFM III, attoCFM I, attoCFM II, attoCFM III, attoRAMAN, atto3DR
- attoAFM/CFM (on request)

CUSTOMER FEEDBACK

Prof. A. Holleitner

We are absolutely happy with the cooling performance of the attoDRY2100, both concerning base temperature as well as duration to cool it down from room temperature! Therefore, many thanks for developing such a great system!

(Technical University Munich, Germany)

Application examples

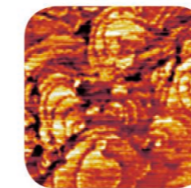

Conductivity Mapping

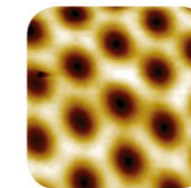

Vortex Imaging

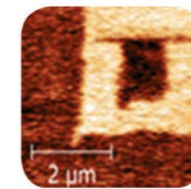

Multi-Ferriox Characterization

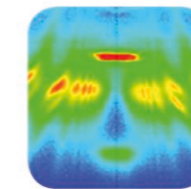

Quantum Dot Spectroscopy

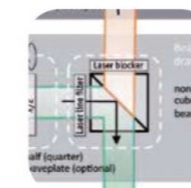

Resonant Fluorescence



Transport Measurements

1.65 K Continuous Operation

exceptional cooling performance

COOLDOWN TIME

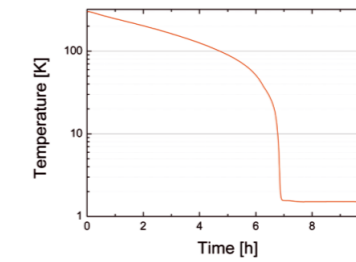

TEMPERATURE STABILITY

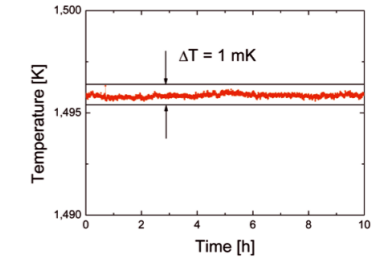

General Specifications	
technology	ultra-low vibration, pulse-tube based closed-cycle cryostat designed for scanning probe microscopy applications
sample environment	HE exchange gas
sample space	49.7 mm diameter probe bore fitting all attocube inserts
sample exchange	top loading system for quick access
vibration & acoustic noise damping system	proprietary low vibration design
usability	automated temperature and magnetic field control via integrated touchscreen, USB interface for remote control
Performance Data*	
temperature range	1.65 .. 300 K (automated control)
base temperature	1.65 K (expected), 1.8 K (guaranteed)
cool down time of sample	3 .. 7 h (depending on insert)
initial cool down time of system without insert (unattended)	15 .. 20 h (system without magnet), 20 .. 24 h (incl. 9 T magnet)
temperature stability	< ± 5 mK expected (1.5 .. 10 K) < ± 10 mK guaranteed (1.5 .. 10 K)
cooling power at sample location	> 2 mW @ 2 K
Closed-cycle cooler	
nominal cooling power (4.2 K)	> 900 mW
power consumption	max. 9.0 kW, 7.2 kW steady state
cooling of compressor	water cooling (requires local infrastructure)
Dimensions	
cryostat (width x depth x height)	1120 x 640 x 1050 mm ³ (depending on magnet choice)
optional electronics rack (width x depth x height)	640 x 640 x 1050 mm ³
Options	
superconducting magnet	solenoids: 7, 9, 12 T vector magnets: e.g.: 8/2 T, 9/3 T, 9/1/1 T, ...
bipolar magnet power supply	included (with optional magnet)
temperature controller	included
pumping kit	turbomolecular pump with suitable backing pump for sample space preparation

*Note: All product specifications are based on a standard system. Optional items or upgrades, other configurations or customization may change one or several of the indicated values. Specifications and other information subject to change without notice.

21st Century User Interface

touchscreen control of field and temperature

Via the integrated 4.3" capacitive touchscreen, the attoDRY1100&2100 cryostats provide a convenient and intuitive interface for a state-of-the-art user experience. The desired sample temperature T and magnetic field B can be set easily by virtually pressing a button directly at the cryostat, enabling a true set-and-forget type of operation. Of course, more elaborate measurement schemes such as programmable sweeps of T and B are also possible via the USB interface and LabVIEW®.



Simply enter your desired values for field and temperature via the numpad screen.



Temperature / magnetic field control options: manual or automatic PID, persistent mode on / off.

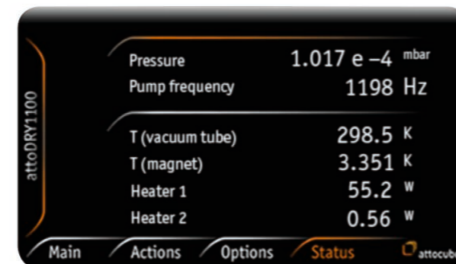

Status screen: monitor the pressure and pump frequency of the integrated turbomolecular pump as well as heater powers and temperatures of the cooling stages.

Selected Measurements

attoDRY2100

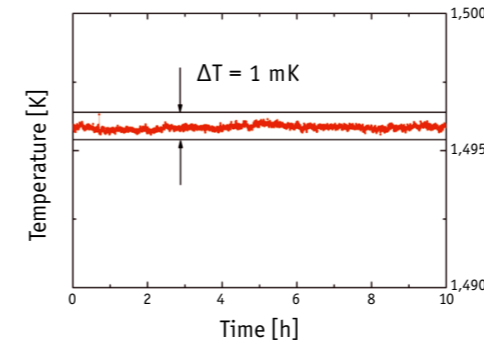

The perfect dry VTI: 9T at 300 K, excellent temperature stability & field cooling

Investigating samples at variable temperatures and magnetic fields is a common task in physics and materials science. Using the attoDRY2100, a closed-cycle cryostat with superconducting magnet, researchers can easily access the whole phase space of temperature between 1.65 K and 300 K as well as magnetic field, usually -9 Tesla to +9 Tesla (others on request) without compromises on performance. The cooldown time of an insert is about 3 .. 7 hours.

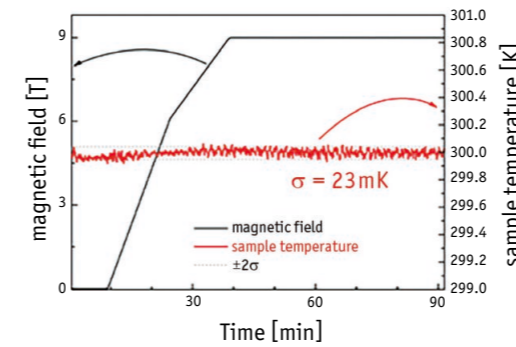

The attoDRY2100 is not only capable of reaching the full magnetic field even at 300 K sample temperature with an excellent temperature stability (10 mK), but also features the possibility of field cooling a sample. The whole temperature and magnetic field control is automated, accessible via the integrated touchscreen or remotely via LabVIEW or a dll.

In the measurements shown to the left, the attoDRY2100 with an atto3DR transport measurement insert was first set to a target sample temperature of 300 K, and then the magnetic field was ramped up from zero Tesla all the way to the full 9 Tesla. This took about 40 minutes. During this process, the sample temperature was stable to within sigma = 23 mK. At 9 T and 300 K, the temperature stability was even better at sigma = 10 mK over more than 6 hours. Subsequently, the sample was field cooled at 9 T back down to base temperature, which took about 3.5 hours.

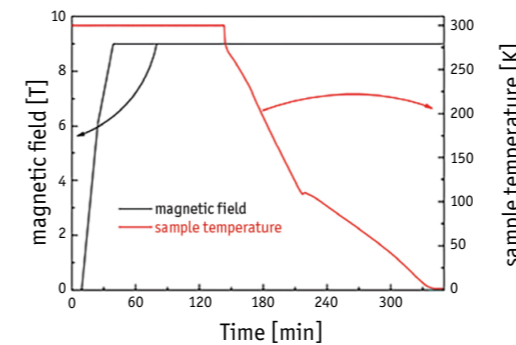

Optional CFM Base Kit for Magneto-Optics

attoDRY1000/1100/2100 options

While many researchers opt for a complete and carefree system solution, others prefer to work on the basis of their own vast experience with homebuilt setups. The latter involves a substantial investment into development time within the research group, but adds to the flexibility of the setup and of course does save the researcher some costs initially.

It is for this reason that attocube also offers CFM base kits for the experts, based on our proven optics components. Instead of a fully tested complete setup, the customer receives the components of his choice for building his own dream setup. Combine a basic measurement insert in our patented design with the wiring of your choice, the world's only low temperature compatible apochromatic objectives with suitable broadband collimator and our patented nanopositioners with a sample holder to kick-start your laboratory!

This base kit approach allows to equip each attoDRY cryostat with several different optical inserts, each one optimized for a specific experiment. Or, put differently, one insert per researcher!

Broadband collimator



Basis insert incl. cabling

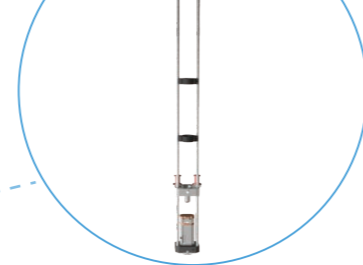

Cryogenic apochromatic objective



Nanopositioners & sample holder



Optional Coupling of Cryostat to Optical Table

combine the convenience of an optical table with fast turnaround time of a topleading magnet system

CUSTOMER FEEDBACK

Prof. David Gershoni

The attoDRY cryostat has been the workhorse of our quantum optics research group over the last 5 years, running almost 24/7. The most convenient feature of the system is the stable coupling between the cryostat insert and our optical table. This feature, which was custom made for us, enables the combination of an elaborate free-beam optical setup with the convenience of an extremely stable, topleading cryostat. The cryostat stability is excellent, and sample turnaround times are kept minimal due to the cryostat design, in which the studied sample is cooled by exchange gas.

(Technion - Israel Institute of Technology, Haifa, Israel)

Add-on for free-beam experiments: Some optical setups (e.g. many time-resolved experiments) include a number of complex optical components mounted on an optical table, before the free-beam is sent onto the cold sample.

For such configurations, attocube offers an optional anchoring of the attoDRY1000/1100 to the optical table. It defines a fixed reference position between the external optics and the sample inside the cryostat. For seamless interfacing of complex free-beam based optical setups with the cryogenic sample environment and high magnetic fields. The distance between the vertical axis of the inner vacuum tube in the cryostat and the optical table is adjustable.

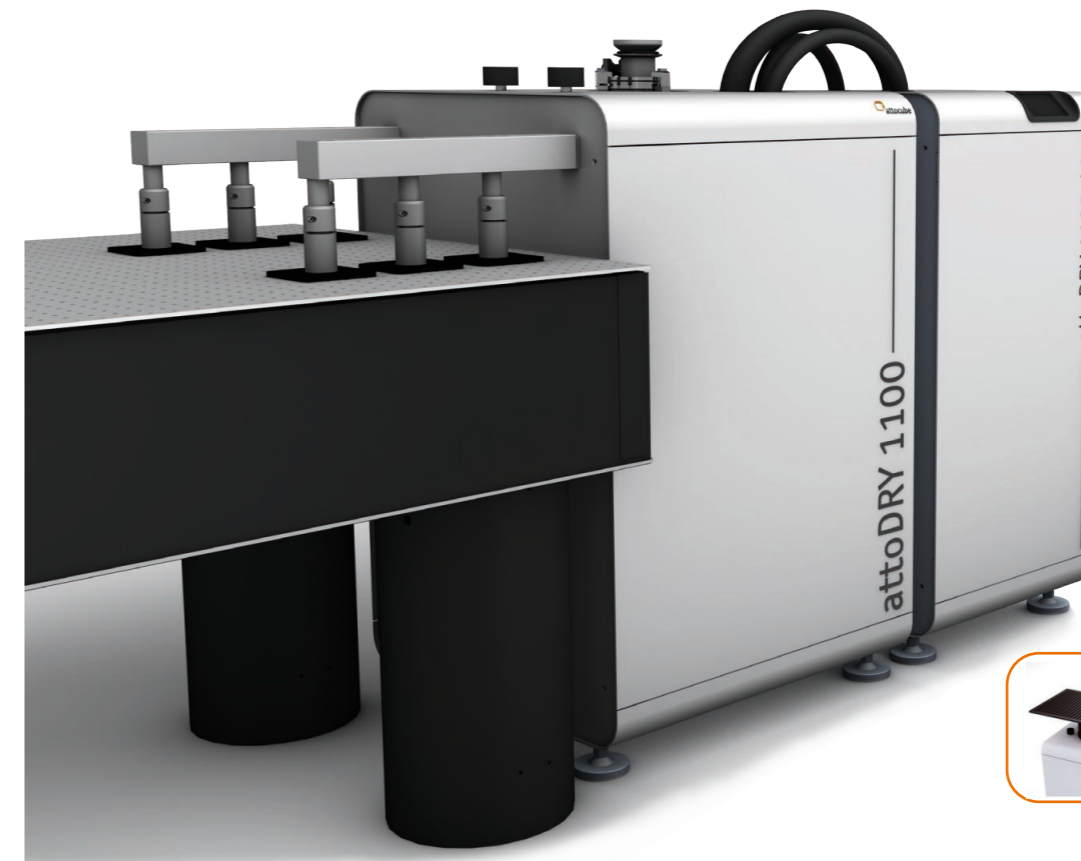

Breadboard add-on also available

Breadboard Add-On with Free-Beam Coupling

attoDRY1000/1100/2100 options

attocube's breadboard add-on offers easy access for challenging optical experiments conducted in cryogenic temperatures and high magnetic fields. Various components can be mounted onto the optical platform, which can be directly attached to any of attocube's top-loading cryostats (attoDRY1000/1100/2100). The elaborate design enables a seamless integration of platform and cryostat, thus offering maximum stability for free-beam experiments.

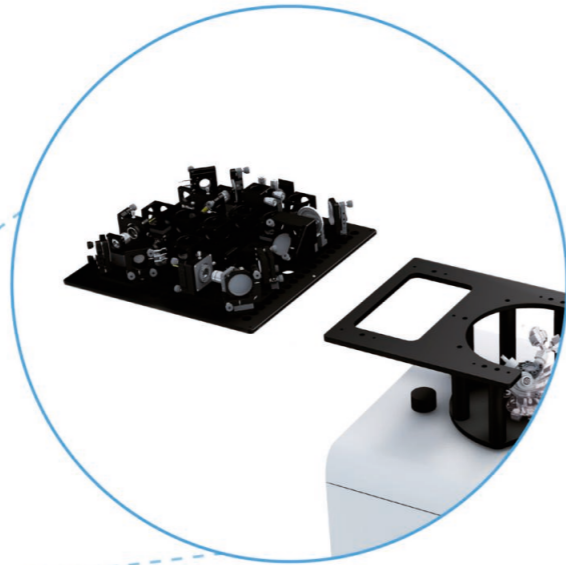

Need more space
for your components?

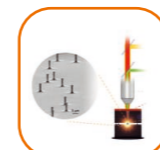

Low temperature
photolithography

CUSTOMER FEEDBACK

Dr. Pascale Senellart

We wanted to modify our cryogenic in-situ lithography setup to a dry cryogenic technology. This setup is our most demanding one, requiring sophisticated multicolor optical alignment and long term stability. attocube's new breadboard add-on to the attoDRY1000 offers great flexibility to our measurements: it provides enough space for three different excitation lines, a camera visualization, and still we can easily add additional optical components like polarization control, etc. Everything worked perfectly well right after installation and we could immediately start again our most demanding resonant fluorescence measurements. The optical stability is even better than before!

(Laboratoire de Photonique et de Nanostructures, LPN-CNRS, Marcoussis, France)

Mount your Optics Directly on the Cryostat

application example: ultimate flexibility combined with exceptional stability

One of the most impressive examples of how attocube's breadboard add-on for the toploading dry cryostats can help to conduct quite influential science has been set up by the French group around Dr. Pascale Senellart at the Laboratory for Photonics and Nanostructures at CNRS. The group has pioneered a technique called *in-situ* optical lithography at low temperatures which consists of three independent optical channels for confocal microscopy mounted on the breadboard on top of the cryostat.

This application demonstrates the unique flexibility as well as the proven stability of the breadboard add-on, see also the testimonial by Dr. Senellart.

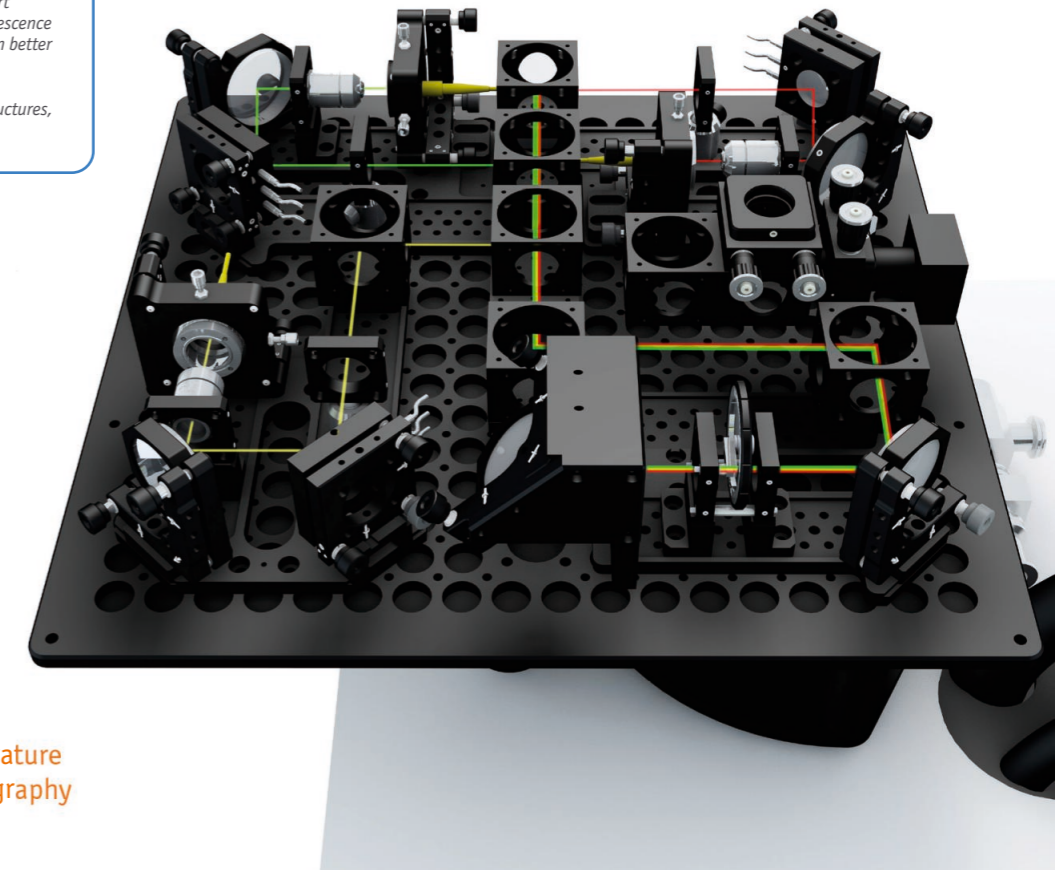



Visit attocRYO online

© 2025, attocube systems GmbH - Germany. attocube systems and the logo are trademarks of attocube systems GmbH. Registered and/or otherwise protected in various countries where attocube systems products are sold or distributed. Other brands and names are the property of their respective owners.

attocube systems GmbH | Eglfinger Weg 2 | 85540 Haar | Germany
Tel.: +49 89 420 797 - 0 | info@attocube.com
www.attocube.com