

Measurement Tools for mK

scanning probe microscopes & nanopositioners



The milli-Kelvin Challenge

enabling fundamental research near absolute zero



Recent advances in various branches of solid state physics have led to a growing interest in performing quantum optics, quantum opto-mechanics, scanning probe microscopy (SPM) and angle-dependent magneto-transport measurements in the sub-100 mK regime, where many emergent phenomena reside. The quest for elucidation of the latter has spurred the interest in dilution refrigerators (DRs). Recent surge in funding for quantum computing has only boosted this interest further.

Milli-Kelvin measurements have been established for ~60 years, especially for electrical transport. However, even without any moving parts, such experiments are extremely delicate due to limited cooling power, long cooling cycles, and used to require comprehensive know-how in handling the accompanying complex setups.

Yet, over the last decade, closed-cycle (so-called dry) DRs have become the *de facto* standard for ultra-low-temperature applications, effectively replacing their liquid counterparts.

This has facilitated their spread due to the much improved ease-of-use through automation and independence on liquid helium. However, sensitive experiments involving nanopositioning of tips and samples have become even more challenging due to the vibrations induced by the cold heads of the pulse tube coolers which provide precooling in two stages down to 40 K and 4 K.

Therefore, while the cooling to ultra-low temperatures itself has become readily available, delicate experiments such as SPM are still extremely challenging. attocube has gained substantial experience with LT-SPM over the last 20 years, and is able to offer expert service on all levels: 30% of our employees hold a PhD in a scientific field related to our customers' research. As a result, everyone in our sales team, project leaders in production, and our after-sales support team are dedicated to understand your applications, and to help you achieve your scientific goals utilizing our technology.

attocube is your reliable partner in enabling fundamental research near absolute zero.

Fields of Applications

enabling fundamental research near absolute zero

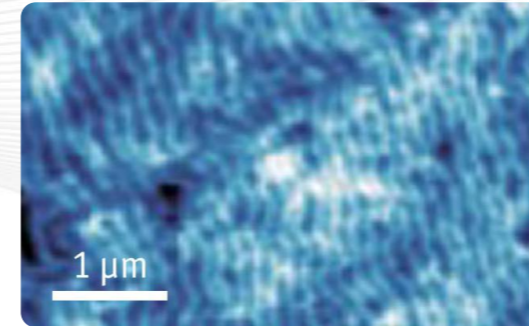

Surface Science

Scanning probe microscopy offers high sensitivity and nanoscale resolution, and attocube microscopes extend those unique capabilities to mK environments and high magnetic fields. This opens the door to a plethora of interesting quantum phenomena, which occur at energy scales so small that they can be observed only at ultra-low temperatures.

Magneto-transport Measurements

Electrical measurements as a function of temperature and magnetic field often also require control of the direction of the magnetic field with respect to the sample structure. Vector magnets are not only quite costly and cumbersome to operate and remotely control, but also quite limited in the magnitude of their vector field strength. A compact and cost-efficient solution is provided by attocube precise rotators, which allow for angle-dependent magneto-transport measurements in 2D or 3D with the full field of a single solenoid.

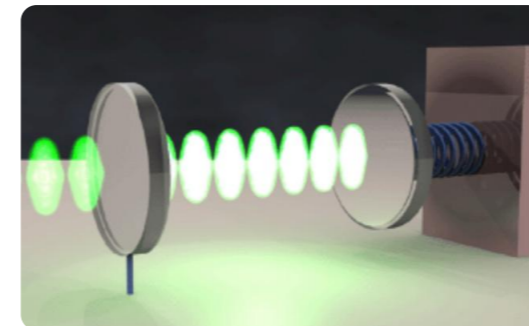

Cavity Physics

Since a few years, it has become possible to prepare macroscopic mechanical oscillators in their groundstate at ultra-low temperatures, which opens the door to sophisticated experiments that couple such quantum resonators to quantum dots, single spins in diamond, or high-finesse optical cavities. These demanding experiments require ultra-precise and extremely stable nanopositioners, which attocube can offer with proven performance.

Platforms for mK Research

state-of-the-art dilution refrigerators with fast sample exchange

Crucial criterion for certain experiments such as scanning probe microscopy is the ability for fast turnaround times for tip and sample exchange. This is possible by using fast sample exchange mechanisms, which are available either the so-called top-loaders, or bottom-loaders (see schematics on the right).

While top-loaders provide slightly higher cooling power, bottom-loaders carry the advantage of significantly lower overall system size, making them the right choice in case of limited ceiling height in existing laboratories. In addition, the cabling in bottom-loaders is routed through the main DR itself, which helps to thermalize the wiring.

Through close collaborations with DR suppliers and leading scientists in several projects over the last 20 years, attocube has gained substantial experience in helping to choose appropriate DRs, providing the right components enabling special applications, and assisting with their integration into the mK environment.

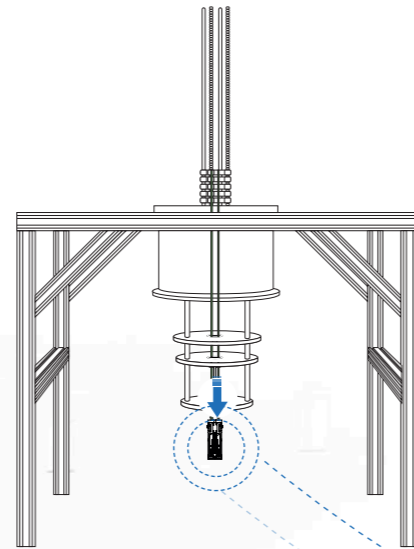

DR with top-loading probe

Top-loading probes constitute the standard solution for fast sample exchange in DRs, which enables both fast turnaround time for sample exchange and high cooling power.

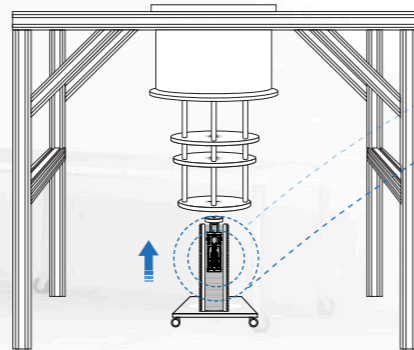

DR with bottom-loading probe

Fast sample exchange via bottom-loading probes further increases the ease-of-use, and significantly decreases the required room height for installation of a DR.

Components & Modules for mK Experiments

scanning probe microscopes and nanopositioners



atto3DR

The 3-dimensional sample rotator module atto3DR enables angle-dependent magneto-transport measurements in high magnetic fields, emulating 3D vector magnets with a single solenoid.

attocube
components & modules



for milli-Kelvin

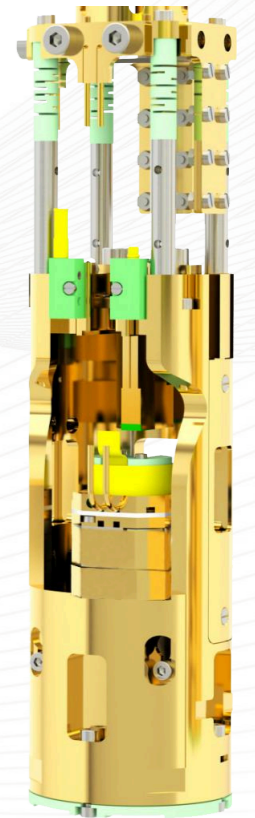

AFM

Atomic force microscopy (AFM) is a great tool for exploring quantum phenomena on the nanoscale. Our AFMs with proven performance at LT are adopted for mK environments, and benefit greatly from fast sample exchange mechanisms of DRs.



Nanopositioners

Precise positioning or scanning of samples, SPM tips, optical fibers or electrical probes can be routinely achieved by our dedicated ultra-low-temperature positioners made from suitable materials.

attocube – Pioneers in Cryogenic Motion

single components, modules & integration support

attocube cryogenic instruments have always been designed for use at low temperatures, hence attocube also offer many microscope modules and nanpositioners as components to enable fundamental research at

mK temperatures. Based on the details of the desired application and its technical requirements, attocube offers to support customers on three different levels:

Components Only

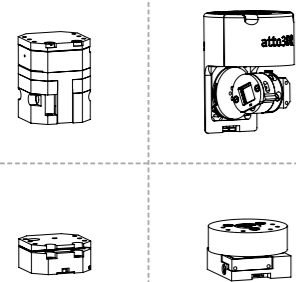

- standard Ti-based or dedicated mK nanpositioners
- providing 3D CAD models to customers

mK-ready Modules

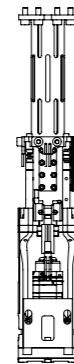

- dedicated mK versions of complete LT microscope modules
- project management to ensure mechanical, thermal & electrical compatibility with the chosen DR
- functionality tests of modules at 4K (not in DR)

Platform Integration

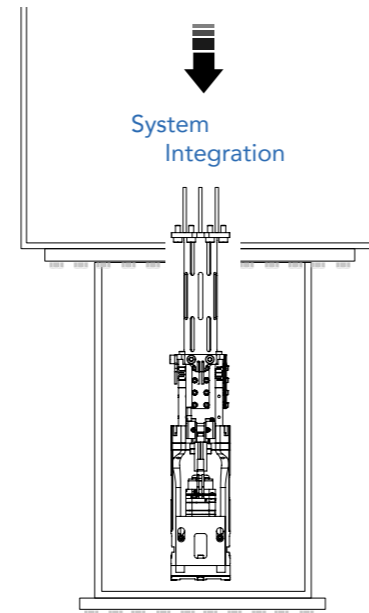

- one supplier for complete setup comprising DR, microscope and all accessories
- comprehensive project management
- factory test of complete setup
- installation and on-site training

Components Only

Components Only

Customers who prefer to build their own mK experiments from scratch can choose from various mK-compatible nanpositioners with proven performance to suit their special requirements. attocube supports these efforts by providing special materials, 3D CAD models, and thermal links.

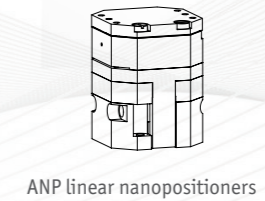
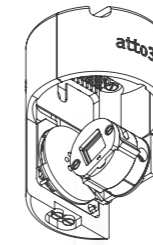

ANP linear nanopositioners

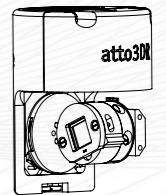

atto3DR double rotator

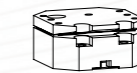

ANG goniometers



ANR rotators



mK Nanopositioners

- most positioner models available for ULT
→ experimental flexibility based on linear positioners, rotators and scanners
- made from beryllium copper
→ non-magnetic with enhanced thermal conductivity
- /RES+ sensor for readout
→ enables reliable position readout below 1 K

Many experiments require nanoprecise motion of samples or probe heads also at mK temperatures. Apart from SPM, based on linear positioners and scanners, such applications would be rotation of mesoscopic samples in magnetic fields, either by 1D or 2D rotators, or using goniometers to tilt samples with respect to, e.g. optical elements. Also, optical fiber probes may have to be positioned *in situ* relative to planar waveguides for investigating photonic circuits such as cavities coupled to superconductors.

Entering the ultra-low temperature regime requires a careful choice of materials and used components. Not only thermal expansion has to be taken into account, but also phase transitions of materials that effect, e.g., thermal conductivity or magnetic properties. Since titanium, the standard non-magnetic material used for our nanopositioners becomes superconducting at about 400 mK, attocube offers linear positioners, rotators and scanners made of beryllium copper.

For better thermal conduction at interfaces, thermal links and sample holders are usually Au plated. Last but not least, the dedicated ' / ULT' positioners are equipped with a special resistive sensor (/RES+). These sensors allow for a reliable readout of absolute position also at temperatures below 1 K.



atto3DR

- *in-situ* eucentric two-axes sample rotation
→ turn single solenoid into strong 3D vector magnet
- chip carrier socket with non-magnetic pogo pins
→ quick sample exchange with reliable contacts
- resistive encoders for closed-loop operation
→ program complex rotation schemes

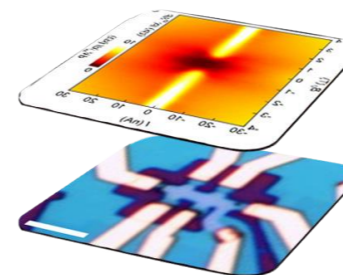

Since split coil magnets are limited to a few Tesla in field strength (e.g. 9-1-1 T or 5-2-2 T) this makes available a much larger phase space as compared to conventional vector magnets, where the field vector is rotated instead. A 12 T single solenoid hence suddenly offers the full 12 T in 3 dimensions when combined with the atto3DR.

When investigating magnetically anisotropic and low-dimensional samples, researchers not only want to vary the magnetic field strength, but also the field direction with respect to the sample. The atto3DR features two piezo-based rotators, which allow for rotation around a horizontally fixed axis, and an additional in-plane axis. This enables a $\pm 90^\circ$ tilt between sample surface and field, as well as another $\pm 90^\circ$ of in-plane rotation. Thus, any relative orientation between sample and field is accessible with a single solenoid and a bipolar magnet powersupply via this eucentric rotation (with both rotator axes intersecting in the field center).

The module comes fully wired and equipped with a convenient leadless ceramic chip carrier (LCCC) socket with 20 contacts, making sample exchange a quick and easy task. The module can be made compatible with almost any dilution refrigerator provided that the sample space diameter is large enough (typically 50 mm; customizations on request). The achievable base temperature of the sample, as well as the thermal anchoring of the rotators to ensure efficient heat transport of the dissipated energy during rotation depends on the cryostat used. For typical results, please contact attocube.

mK-ready Modules

For customers looking for mK-ready microscopes, which they intend to integrate themselves into their dilution refrigerator, attocube offers dedicated mK modules with suitable mechanical, geometrical and thermal interfaces.

To ensure compatibility, an experienced project leader will take over all required communication with the customer and the DR supplier. Factory tests of the module will be conducted in a conventional 4K cryostat.

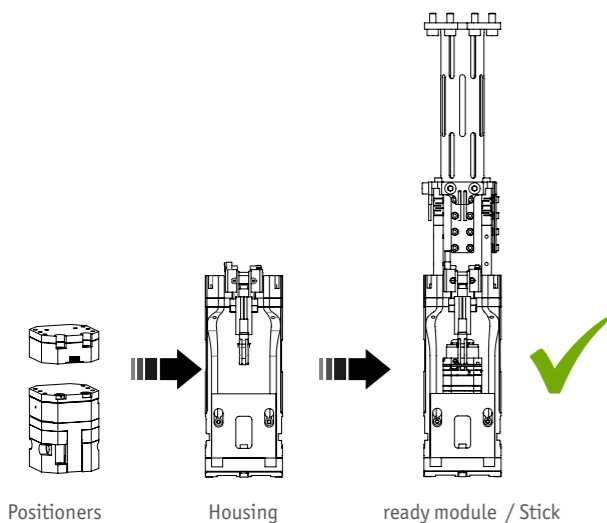

mK Atomic Force Microscopes

- non-magnetic materials with high thermal conductivity
→ ensure mK compatibility
- cantilever-based AFM with interferometric readout
→ suitable for MFM, KPFM, PFM and ct-AFM
- tuning-fork-based AFM
→ suitable for SGM

attoAFM I is a compact atomic force microscope designed particularly for applications at low and ultra-low temperatures, and in high magnetic fields. The instrument works by scanning the sample underneath a fixed cantilever. Due to cantilever-sample interactions, the cantilever is deflected, which is measured with highest precision using a fiber-based Fabry-Pérot interferometer. Both contact and non-contact mode are applicable. attoAFM I is utilized for magnetic force microscopy (MFM), such as magnetic domain imaging at variable temperature or vortex imaging on superconductors, as well as for piezo-response force microscopy (PFM) on ferroelectrics and multiferroics. Other supported AFM measurement modes include Kelvin probe force microscopy (KPFM), conductive-tip AFM (ct-AFM) and electrostatic force microscopy (EFM).

attoAFM III features a non-optical shear force detection based on a tuning fork (TF), which makes it ideally suited for applications where input of light is problematic, either because of light-sensitive samples, or due to the additional heat load and power dissipation generated by a laser-based deflection-detection system. attoAFM III is compatible with wire-type tips glued onto one prong of a small quartz TF, as well as with commercially available TFs with integrated tips. Force resolution is typically 0.1 pN. Typical application is scanning gate microscopy (SGM) on semiconductor structures.

Last but not least, due to the open signal architecture of our powerful and flexible ASC500 SPM controller, the needs of experts are met by having control over all signals. The user-friendly software interface also supports measurement routines based on LabVIEW scripts.



Selected AFM Measurement Modes

Magnetic Force Microscopy (MFM)

MFM uses cantilevers with magnetic coatings which are sensitive to magnetic interactions between tip and sample. Like most MFMs, attoMFM applies an AC actuation of the cantilever to achieve highest sensitivity. The cantilever mechanically oscillates at its natural resonance frequency f_0 in an orientation where its magnetic moment is swinging perpendicularly to the sample surface (z-direction).

Resonance frequency (as well as amplitude and phase) of the cantilever is affected by the magnetic interaction. This frequency shift $\Delta f = f_{res} - f_0$ can be detected by classical lock-in techniques and is the most relevant physical quantity to measure due to its direct proportionality to the derivative of the local force F in the limit of small oscillation amplitudes: $\partial F_z / \partial z \sim 2K\Delta f / f_0$.

The measurement therefore yields a 2D map of actual local magnetic stray field: $\partial F_z / \partial z \sim m_{tip,z} \partial H_z / \partial z$ (where $m_{tip,z}$ is the magnetization of the tip perpendicular to the sample surface) with very high spatial resolution. Using a phase-locked loop (PLL) technique, resonance frequency shifts as small as 1 μ Hz can be detected.

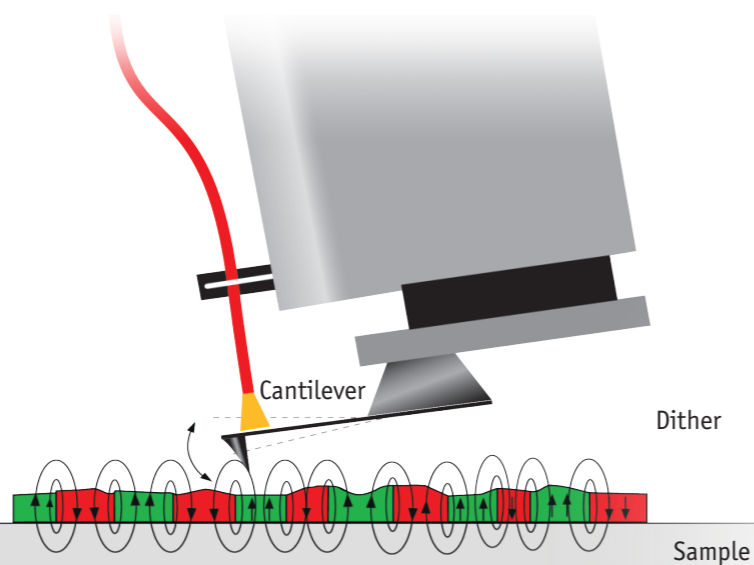

Scanning Gate Microscopy (SGM)

SGM utilizes the ability of an AFM tip to influence the electrostatic properties of a sample locally. By applying voltage to the scanning tip, the tip acts as a movable electrical gate that can modify electrostatic potential for electrons in the sample and thus enables exploring electronic and transport properties at the nanoscale (Figure 1).

This approach has already been proven useful at temperatures > 4 K in e.g. imaging current flow through quantum point contacts [M.P. Jura et al., Nature Phys. 3, 841 (2007)], or in visualizing coherent transport and universal conductance fluctuations in graphene [J. Berezovsky et al., Nanotechnology 21, 274013 (2010)]. By adopting SGM to mK temperatures, quantum phenomena can be probed since electron mobilities further increase along with thermal fluctuations further decreasing, which is the prerequisite for reaching the necessary energy resolution.

Tuning-fork-based AFMs with wire-type tips are better suited for SGM than cantilever-based AFMs, since the cantilever strongly influences the capacitive coupling between tip and sample, and hence washes out the localization of the tip potential. The attoAFM III is the perfect microscope platform for electrical transport measurements on the nanoscale.

Figure 2: A typical potential landscape for a scanning gate experiment on a GaAs/AlGaAs heterostructure. It demonstrates the size of the tip-induced potential as well as the influence of the disorder potential (image courtesy of R. Steinacher, ETH Zurich, Switzerland).

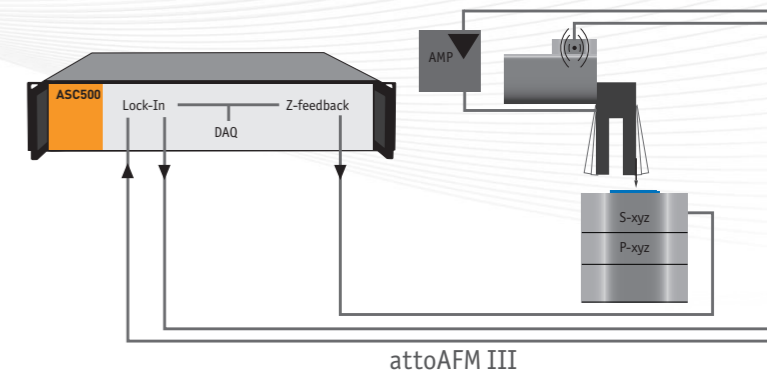

Figure 1

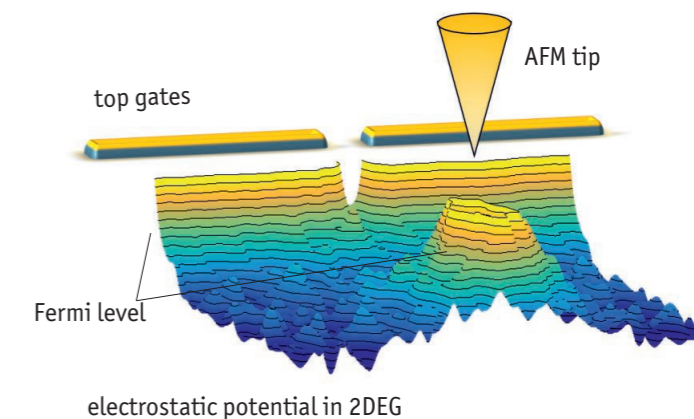
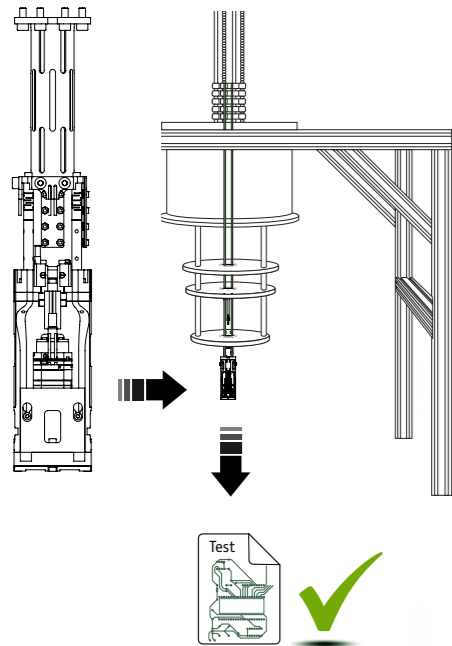

Figure 2

Platform Integration

Based on our experience with several lighthouse projects in collaboration with leading scientists, attocube also offers integration and delivery of complete systems comprising DR, microscope and all accessories.

Comprehensive project management will be conducted by an experienced project leader, including all planning, production, factory testing, on-site installation and training. The availability of this option may depend on the details of DR, SPM technique, and desired application.



Tuning-fork-based AFM for Scanning Gate Microscopy in Top-loading DR

For this project, we have developed a mK tuning-fork AFM for a dry top-loading DR in close collaboration with Bluefors. The DR has a cooling power of ~300 μ W at 100 mK and a base temperature of 8 mK. The cooling power at the sample location on the top-loading insert is 100 μ W at 100 mK. Thanks to the top-loading probe, the turnaround time is typically 9-11 hours, hence tip and sample exchange can be achieved within a reasonable timeframe without warming up the whole DR including the superconducting magnet.

The customized attoAFM III has been carefully adapted for the mK environment in terms of wiring and thermalization, and the whole configuration has been tested and optimized at mK temperatures. The microscope is intended to be used for scanning gate microscopy (SGM), where the wire-type AFM tip on the tuning fork serves as a mobile local gate.

This allows for characterization of electrical transport properties in mesoscopic samples on the nanoscale as a function of gate position and tip potential. Previous implementations of such mK microscopes [1] have involved heavy spring isolation of the microscope inside the DR, which yielded good results. However, it makes the design and practical use much more complicated, since any material shows a finite susceptibility and hence undesired motion in strong magnetic fields.

Despite the top-loading probe design, and despite having no spring isolation on the microscope module, the tuning-fork AFM system reaches 2.9 nm rms z-noise. This is of the same order of magnitude as previously reported [1], where a heavy 6 kg damping stage inside the DR was used. At typical tip-sample distances of a few tens of nanometers, this is well suited for SGM experiments.

[1] M. Pelliccione et al., Rev. Sci. Instrum. 84, 033703 (2013)

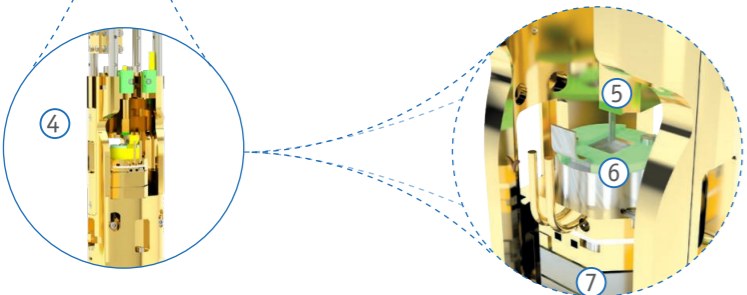

- 01 Bluefors dry dilution refrigerator
- 02 top-loading insert
- 03 superconducting magnet

- 04 attoAFM III microscope for mK
- 05 tuning fork with AFM tip
- 06 chip carrier sample holder with thermalization
- 07 positioners and scanners for sample motion



Customer
Prof. Alexander Hamilton
(University of New South Wales, Australia)

Project
mK AFM III for SGM

Setup:

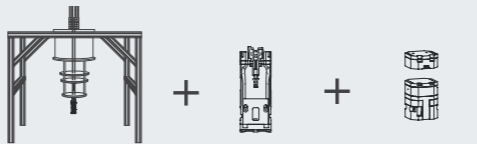

Top-loading DR Bluefors + mK attoAFM III + mK Positioners

AFM/CFM with Free-Beam Optics for NV Magnetometry in Top-loading DR

In close collaboration with Leiden Cryogenics and the Quantum Sensing group of Patrick Maletinsky (University of Basel, Switzerland), we have developed a complete mK AFM/CFM based on a closed-cycle top-loading DR. The system is used for quantum sensing and imaging at mK temperatures. The top-loading probe minimizes the turnaround time upon tip or sample exchange to only ~8 hours instead of 24-48 hours for warming up the whole DR. Long turnaround time can quickly become a prohibitive shortcoming for efficient SPM measurements.

The combined AFM/CFM features a free-beam confocal microscope, with the attoCFM I external optics head sitting on top of the top-loading insert.

Despite long distance to the magnetic field center where the sample is mounted, attoAFM/CFM allows for the full range of confocal applications with all the flexibility of having several optical channels featuring easy alignment and very high long-term stability. The microscope module itself has been completely redesigned for the mK environment, as well as carefully thermalized and wired. In this configuration, a base temperature of 38 mK at the sample location has been achieved.

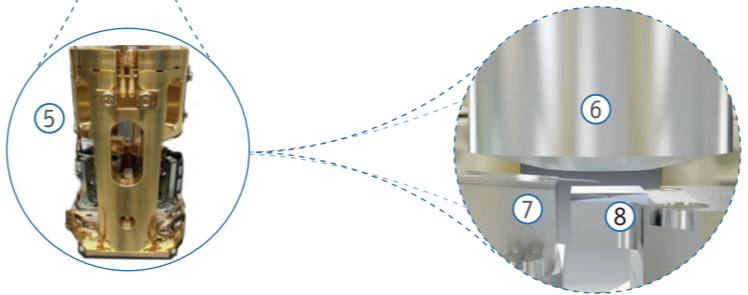
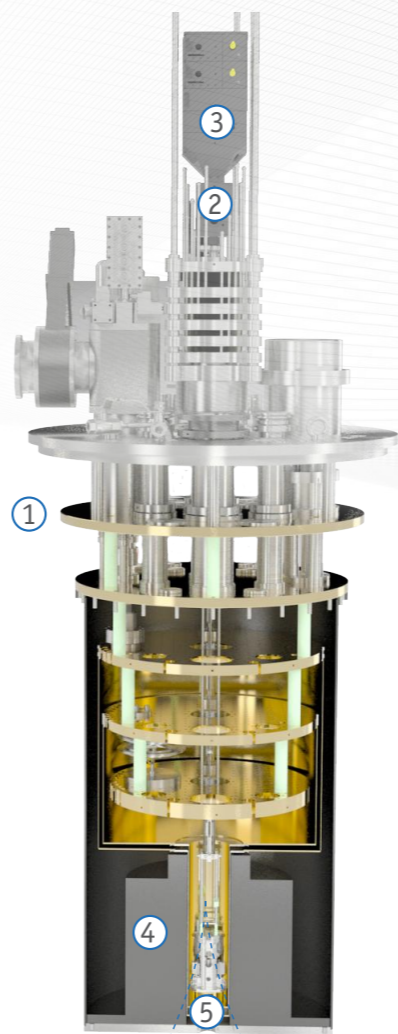

- 01 Leiden Cryogenics dry DR
- 02 top-loading insert
- 03 attoCFM I external optics head for free-beam confocal microscopy

- 04 vector magnet
- 05 attoAFM/CFM microscope module for mK
- 06 cryogenic objective
- 07 AFM with the Akiyama probe
- 08 sample



Customer
Prof. Patrick Maletinsky
(University of Basel, Switzerland)

Project
mK AFM/CFM for NV Magnetometry

Setup:

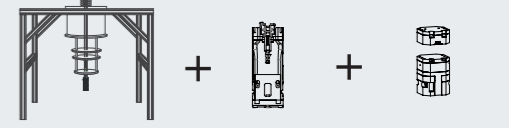

Top-loading DR Leiden Cryogenics + mK AFM/CFM + mK Positioners

Selected Applications

scanning probe microscopy at mK temperatures

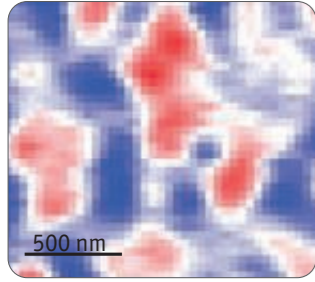

Quantized Conduction on Domain Walls of a Magnetic Topological Insulator

In a paper published in Science, researchers from the University of Tokyo and RIKEN (Japan) have studied quantized conduction on domain walls of a magnetic topological insulator using an attoAFM/MFM in a 3He-cryostat down to 500 mK. In their paper, Yasuda et al. designed and created magnetic domains in the quantum anomalous Hall state, and proved the existence of the chiral one-dimensional edge conduction along the domain walls through transport measurements. This discovery would permit fully electrical control of the mobile domain walls and chiral edge states, which may lead to the realization of low-power-consumption spintronic, memory and quantum information processing devices in the future.

Further Readings:

[1] K. Yasuda et al., *Science* 358, 1311 (2017)

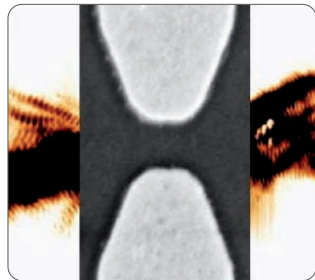

Scanning Gate Microscopy at 300 mK

In this measurement, an attoAFM III was operated inside an attoLIQUID3000 cryostat at 300 mK in scanning gate microscopy mode (SGM) - investigating the trajectory and interaction of edge channels of a split-gate quantum point contact (QPC) device in the quantum Hall (QH) regime. By scanning the SGM tip over the surface of the QPC at constant height and by simultaneously measuring and plotting the source-drain current, conductance maps were obtained. The image to the left is an example of such a conductance map depicting the characteristic branched-flow of electrons at zero magnetic field, which in turn shows electron interference fringes and the actual electron path ($T = 400$ mK, 2DEG density $n_{2D} = 3.37 \times 10^{11} \text{ cm}^{-2}$)

Further Readings:

[1] N. Paradiso et al., *Physica E* 42, 1038 (2010)

[2] N. Paradiso et al., *Phys. Rev. Lett.* 108, 246801 (2012)

[3] L. Bours et al., *Phys. Rev. B* 96, 195423 (2017)

Selected Applications

scanning gate microscopy at mK temperatures

attoAFM/CFM on Top-loading Insert

This data was taken with a mK-compatible version of the attoAFM/CFM mounted in a top-loading insert of a Leiden Cryogenics closed-cycle DR. The sample temperature was 60 mK during an AFM scan with the speed of 400nm/s. The images nicely demonstrate that the delicate microscope works very well even under these extreme conditions.

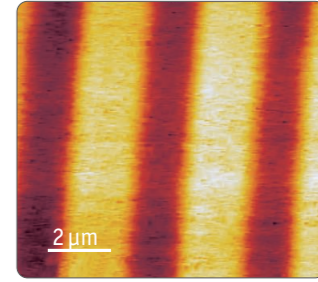

attoAFM III on Top-loading Insert

This data was taken with a tuning fork attoAFM III specifically designed for mK operation. The extremely sensitive microscope was mounted in a top-loading insert, which ensures a much higher usability in terms of turnaround times upon tip and sample exchange than in case of microscope being mounted directly on the mixing chamber. The sample temperature in the top-loading DR was 55 mK during the scan at 100 nm/s. The images nicely demonstrate that the delicate microscope works reasonably well even under these extreme conditions.

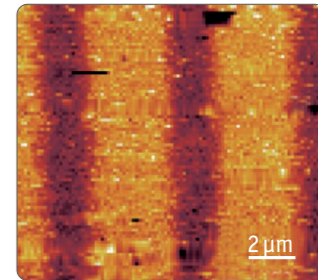

Technical Background for mK Setups

effects of resistive wiring

Unlike in 4K-cryostats, heating effects become a major issue when reaching mK temperatures. Main sources of heating caused by attocube positioners are: dissipating power from engaging the actuator, ohmic

heating due to finite resistance of the piezoelement, and thermal connection to RT due to wiring.

Wiring of an attocube Piezo Positioner & Effects of Resistive Wiring

The electrical signal applied to the piezo element consists of a slow rise and a steep drop (sawtooth signal). Increasing the resistance of the connected wire causes the sawtooth signal to smear out. A sharp transition is essential for the movement of the positioner.

In general, attocube suggests to use copper (typ. $0.7 \Omega/\text{m}$ @ 0.2 mm diameter) or brass wiring (typ. $1.5 \Omega/\text{m}$ @ 0.25 mm diameter) with a total resistance (both wires) of not more than 2Ω (bandwidth 100 kHz). In this case, attocube fully guarantees the functionality and the specifications of the positioners. With a resistance of $2 - 5 \Omega$ some specifications might be altered (e.g. max. load, min. step size, etc.) but the general functionality of the positioner is kept. If the resistance of the wires is between 5 and 10Ω it is recommended to contact attocube.

Such wiring specifications are often in conflict with the requirements for mK setups because of the high specific heat values of the materials used. Therefore, for mK setups attocube uses a combination of copper wires and superconducting or phosphor-bronze wires.

To balance the thermal and the resistive load, copper wires are typically used from RT down to the 4 K stage or the 1 K pot. From there, either superconducting NiTi wires or phosphor-bronze wires lead to nanopositioners. Phosphor-bronze wires allow for the testing of the complete setup at RT, where superconducting wires have very high resistance. attocube's strategic DR suppliers already offer standardized low-resistance cabling for attocube nanopositioners. Furthermore, in order to reduce the heat load on the sample stage, the total number of wires for nanopositioners, as well as for scanners, is reduced by using a shared ground.

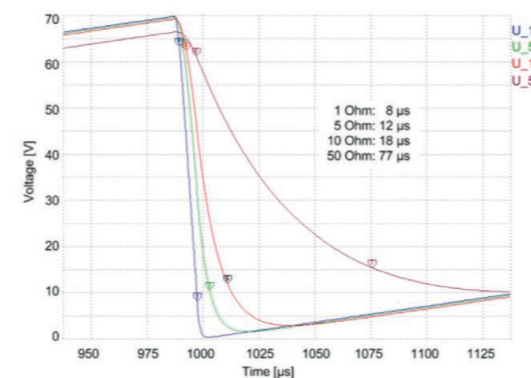

Shape of the steep flank of the sawtooth signal as a function of the total wire resistance.

Technical Background for mK Setups

power dissipation and leakage currents

Power Dissipation

The power dissipation of the capacitive piezoelement is another source of generated heat at ultra-low temperatures. A Piezo dissipates the power $P = fCU^2 \tan\delta$ with the total power P , maximum voltage U , piezo capacitance C , signal repetition rate f , and loss angle δ of the dissipated electrical power.

For example, with $C = 200 \text{ nF}$, $f = 10 \text{ Hz}$, $U = 70 \text{ V}$, and $\tan\delta \approx 4\%$ the heat generated calculates to $P = 490 \mu\text{W}$. In case of a rotator, this number gets doubled because there are two piezoelements used to drive these positioner types.

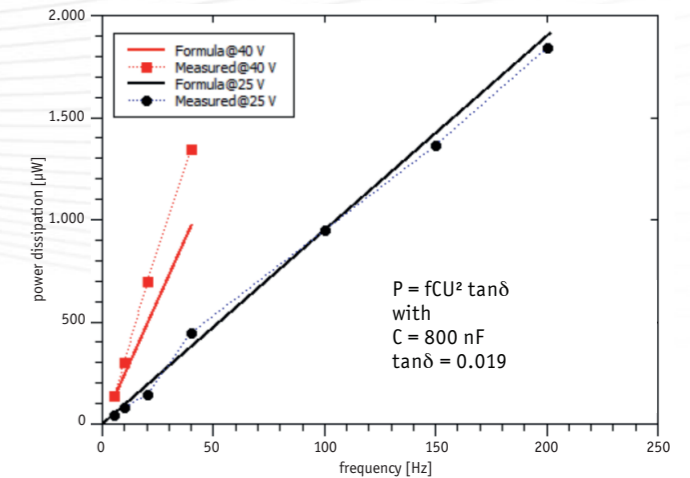

Comparison between calculated and measured power dissipation.

Leakage Currents

Piezoelements typically have $\text{G}\Omega$ resistances. Even with e.g. $1 \text{ G}\Omega$ resistance, the heating due to leakage currents at 100 V static voltage is order of $P = U^2/R = 10 \mu\text{W}$. This leakage current can only be reduced by using elements with higher ohmic resistances. attocube ensures a reduced leakage current by hand-selecting the piezoelements for dedicated mK positioners.

Strategic Partners

strong collaborations with leading suppliers to help pushing boundaries

Bluefors

Bluefors specializes in cryogen-free DR systems with a strong focus on the quantum computing and information community. The company's aim is to deliver the most reliable and easy-to-operate DRs on the market achieving highest possible quality. Bluefors offers a wide range of standard systems with various options including wiring and superconducting magnets.

In addition their systems can be customized to meet the requirements of each individual customer. attocube and Bluefors are closely collaborating to help establishing standard platforms and solutions for mK scanning probe microscopy and mK rotators integrated into their DRs for reliable operation.

BLUEFORS

Leiden Cryogenics

Leiden Cryogenics was founded in 1992 by Giorgio Frossati and Alex Kamper, and is specialized in supplying cutting-edge DRs with ultimate specifications. The machines have obtained several World record of lowest temperatures, and are renowned for their unique fit to even most challenging research tasks. With a personal experience of 50 years, Prof. Frossati keeps pushing the limits in dry mK technology. attocube & Leiden Cryogenics have worked together on several large projects concerning mK scanning probe microscopy successfully.



PrimeNano

PrimeNano's LT ScanWave™ enables research on quantum effects, phase transitions and novel materials such as topological insulators, ferroelectrics or manganites. Based on the attoAFM I, this system enables scanning microwave impedance microscopy (sMIM) measurements on the nanoscale for electrical characterization of materials at ultra-low temperatures and high magnetic fields. PrimeNano and attocube have developed a platform that enables such measurements at mK temperatures.

PRIMENANO

Highest Resolution Electrical Measurements

Enabling Scientific Impact

selected mK customer publications



Title	Journal	Authors
Nonlinear optics in the fractional quantum Hall regime	Nature 572, 91 (2019)	P. Knüppel et al.
An integrated nanophotonic quantum register based on silicon-vacancy spins in diamond	Phys. Rev. B 100, 165428 (2019)	C.T. Nguyen et al.
Piezo-driven sample rotation system with ultra-low electron temperature	Rev. Sci. Instrum. 90, 023905 (2019)	P. Wang et al.
Signatures of tunable superconductivity in a trilayer graphene moiré superlattice	Nature 572, 215 (2019)	G. Chen et al.
Full electrostatic control of quantum interference in an extended trenched Josephson junction	Phys. Rev. B 99, 235419 (2019)	S. Guiducci et al.
Polaron polaritons in the integer and fractional quantum Hall regimes	Phys. Rev. Lett. 120, 057401 (2018)	S. Ravets et al.
Manipulating quantum Hall edge channels in graphene through scanning gate microscopy	Phys. Rev. B 96, 195423 (2017)	L. Bours et al.
Quantized chiral edge conduction on domain walls of a magnetic topological insulator	Science 358, 1311 (2017)	K. Yasuda et al.
Superconducting and ferromagnetic phase diagram of UCoGe probed by thermal expansion	Phys. Rev. B 95, 115151 (2017)	A. M. Nikitin et al.
Rotational symmetry breaking in the topological superconductor Sr _x Bi ₂ Se ₃ probed by upper-critical field experiments	Sci. Rep. 6, 28632 (2016)	Y. Pan et al.
Global and local superconductivity in boron-doped granular diamond	Adv. Mater. 26, 2034, (2014)	G. Zhang et al.
Observing vortex motion on NbSe ₂ with STM	Physica C 503, 154 (2014)	M. Timmermans et al.
Dynamic visualization of nanoscale vortex orbits	ACS Nano 8, 2782 (2014)	M. Timmermans et al.
Design of a scanning gate microscope in a cryogen-free dilution refrigerator	Rev. Sci. Instrum. 84, 033703 (2013)	M. Pelliccione et al.
Imaging fractional incompressible stripes in integer quantum Hall systems	Phys. Rev. Lett. 108, 246801 (2012)	N. Paradiso et al.
Quantum quench of Kondo correlations in optical absorption	Nature 474, 627 (2011)	C. Latta et al.
Piezoelectric rotator for studying quantum effects in semiconductor nanostructures at high magnetic fields and low temperatures	Rev. Sci. Instrum. 81, 113905 (2010)	L. A. Yeoh et al.
Selective control of edge-channel trajectories by scanning gate microscopy	Physica E 42, 1038 (2010)	N. Paradiso et al.



attocube

WITTENSTEIN group

© 2024, attocube systems AG - Germany. attocube systems and the logo are trademarks of attocube systems AG. Registered and/or otherwise protected in various countries where attocube systems products are sold or distributed. Other brands and names are the property of their respective owners.

attocube systems AG | Eglfinger Weg 2 | 85540 Haar | Germany
Tel.: +49 89 420 797 - 0 | info@attocube.com
www.attocube.com

Brochure version: 2024 - 01